

JUKI[®]

Computer-controlled Cycle Machine with Input Function

入力機能付き電子サイクルマシン

AMS-224E/IP-410

PARTS LIST

CSTMP

40072222

No.1509-01

HOW TO MAKE USE OF THIS PARTS LIST

1.Explanation of codes

1)"*"mark.....means this part is changed from the previous parts book.

As to the details of the change, refer to "List for information of change".

2)"#01".....refer to "Note" explanation at bottom of page.

2.Codes on the "Qty" column

- Each numeral indicates the number of parts required.
- "0.1" and "2.5" indicate the length (in meters) of the respective parts.

3.Parentheses mean that the corresponding part is a subpart that constructs an assembly part.

4.Dotted lines on the Figures indicate assembly parts.

5.As to the parts with marks of "☆"(consumable parts) and "◎"(optional parts) on the respective parts, it is recommended to prepare spares.

パーツリストご利用に際して

1."注記"欄の記号説明

1)"*"印..... 前回のパーツブックに比較して今回変更された部品を意味します。
変更内容は"変更情報リスト"を参照してください。

2)"#01"..... ページ下の"注記"の説明を参照してください。

2.数量欄の数字は、個数を表し、0.1、2.5等の数値は、長さ(単位メートル)を表します。

3.数量欄の()は、組部品を構成している子部品であることを意味します。

4.イラストページの-----枠は、組構成であることを意味します。

5.リストページの"☆"(消耗部品)、“◎”(オプション部品)の印がついた部品は、
予備を準備しておくことをお勧めします。

CONTENTS

目次

1. FRAME & MISCELLANEOUS COVER COMPONENTS (1).....	1
頭部・外装関係 (1)	
2. FRAME & MISCELLANEOUS COVER COMPONENTS (2).....	3
頭部・外装関係 (2)	
3. FRAME & MISCELLANEOUS COVER COMPONENTS (3)(FOR 4530).....	5
頭部・外装関係 (3) (4530用)	
4. FRAME & MISCELLANEOUS COVER COMPONENTS (4)(FOR 6030).....	7
頭部・外装関係 (4) (6030用)	
5. MAIN SHAFT & NEEDLE BAR COMPONENTS	9
上軸・針棒関係	
6. PRESSER MECHANISM & PRESSER VARIABLE COMPONENTS (1).....	11
中押え・中押え可変関係 (1)	
7. PRESSER MECHANISM & PRESSER VARIABLE COMPONENTS (2).....	13
中押え・中押え可変関係 (2)	
8. SHUTTLE DRIVER SHAFT COMPONENTS (1)	15
下軸関係 (1)	
9. SHUTTLE DRIVER SHAFT COMPONENTS (2)	17
下軸関係 (2)	
10. WIPER MECHANISM COMPONENTS.....	19
ワイパー関係	
11. TENSION RELEASE & THREAD TENSION COMPONENTS.....	20
糸ゆるめ・糸調子関係	
12. THREAD TRIMMER MECHANISM COMPONENTS.....	21
糸切り関係	
13. THREAD CLAMP COMPONENTS	23
糸掴み関係	
14. X-Y COMPONENTS (1)(FOR 4530).....	25
X - Y 関係 (1) (4530用)	
15. X-Y COMPONENTS (2)(FOR 6030).....	27
X - Y 関係 (2) (6030用)	
16. X-Y COMPONENTS (3).....	29
X - Y 関係 (3)	
17. CLOTH FEED MECHANISM COMPONENTS.....	31
布送り台関係	
18. PNEUMATIC COMPONENTS	33
工ア一関係	
19. THREAD STAND COMPONENTS.....	34
糸立て装置関係	
20. OPERATION PANEL COMPONENTS.....	35
操作パネル関係	

21. CONTROL BOX COMPONENTS	37
電装ボックス関係	
22. WIRING DIAGRAM	39
電装配線図	
23. TABLE COMPONENTS	41
脚卓関係	
24. PEDAL COMPONENTS	43
ペダル関係	
25. ACCESSORIE PART COMPONENTS	44
付属品関係	
26. TYPE G EXCLUSIVE PARTS	45
G仕様専用部品	
27. SEPARATE STROKE TYPE EXCLUSIVE PARTS	46
2段ストローク仕様専用部品	
28. LIST FOR INFORMATION OF CHANGE	47
変更情報リスト	
NUMERICAL INDEX OF PARTS	48
索引	



1. FRAME & MISCELLANEOUS COVER COMPONENTS (1)

頭部・外装関係 (1)

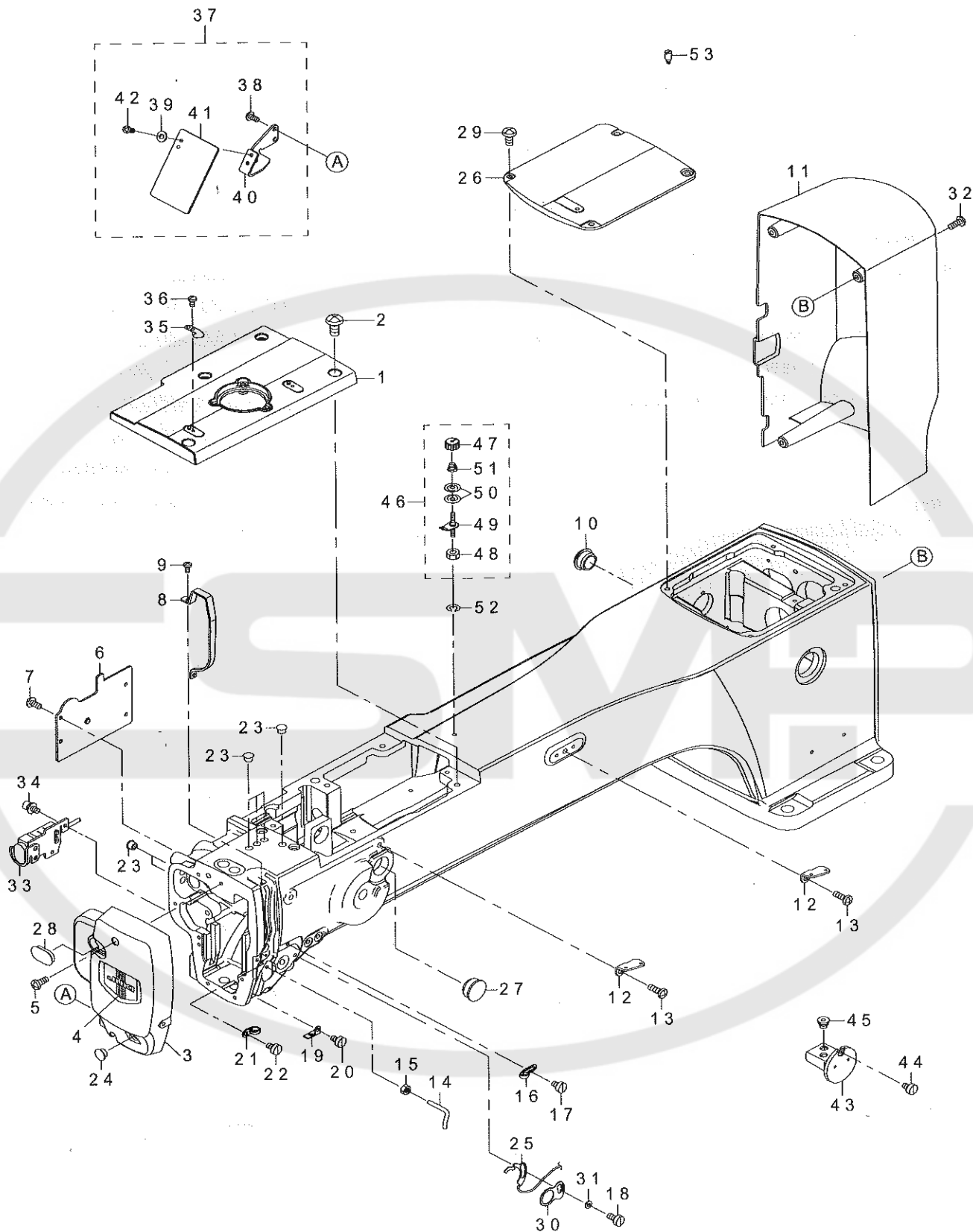

REF.NO	NOTE	PART NO	DESCRIPTION	品名	Qty
1		400-32158	TOP_COVER_FRONT	上面カバー 前	1
2		SM-4061255-SP	SCREW M6 L=12	なべねじ M6 L=12	4
3		400-26979	FACE_COVER	面部カバー	1
4		229-02506	FACE PLATE	面板化粧板	1
5		SM-4041055-SP	SCREW	なべねじ M4 L=10	2
6		400-24999	PRESSER_COVER	中押えカバー	1
7		SM-4040855-SP	SCREW	なべねじ	4
8		400-30828	THREAD_TAKE_UP_LEVER_COVER	天秤カバー	1
9		SM-4030601-SN	SCREW M3 X 6	なべ小ねじ M3 X 0.5 L=6	2
10		TA-2100904-R0	RUBBER PLUG	止栓	1
11		400-27971	MOTOR_COVER	モータカバー	1
12		262-11904	THREAD GUIDE PLATE	第二糸案内	2
13		SM-4061255-SP	SCREW M6 L=12	なべねじ M6 L=12	2
14		400-25414	L_SHAPED_THREAD_GUIDE	L型糸案内	1
15		NM-6040000-SN	NUT M4	六角ナット M4	1
16		229-20508	ARM_THREAD_GUIDE_A	アーム糸案内 A	1
17		SM-6040650-TP	SCREW	平ねじ M4 L=6	1
18		SM-6040860-TP	SCREW M4 L=8	平ねじ M4 L=8	1
19		B1129-210-000	FRAME_THREAD_GUIDE (B)	アーム糸案内 B	1
20		SM-6040650-TP	SCREW	平ねじ M4 L=6	1
21		137-05108	TAKE-UP_THREAD_GUIDE_B	天秤糸案内 B	1
22		SM-6040650-TP	SCREW	平ねじ M4 L=6	1
23		TA-0850604-R0	RUBBER PLUG	止栓	6
24		TA-1050504-R0	RUBBER PLUG	止栓	1
25		400-73678	THB_SENSOR_CABLE_ASM.	糸切れセンサケーブル組	1
26		400-32159	TOP_COVER_REAR	上面カバー 後ろ	1
27		TA-2351004-R0	RUBBER PLUG	止栓	1
28		400-28877	FACE_COVER_CAP	面部カバー止栓	1
29		SM-4051055-SP	SCREW	なべねじ	4
30		400-28834	GUIDE_PLATE	糸切れ検知板ガイド	1
31		400-28835	BUSHING	糸切れ検知板ブッシュ	1
32		SM-4041055-SP	SCREW	なべねじ M4 L=10	4
33		400-73676	STOP_SW_ASM	一時停止スイッチ組	1
34		SL-6040892-TN	BOLT	座金付き六角穴ボルト	2
35		105-02300	THREAD CUTTER	糸切り保持板	1
36		SM-4030601-SN	SCREW M3 X 6	なべ小ねじ M3 X 0.5 L=6	1
37		400-06484	SAFETY_PLATE_COMPL.	安全プレート結合	1
38		SM-4040855-SP	SCREW	なべねじ	(2)
39		WP-0450801-SD	WASHER 4.5X10X0.8	平座金 4.5 X 10 X 0.8	(2)
40		400-51987	SAFETY_PLATE_BASE	アイガード固定板	(1)
41		B3120-372-000	SAFETY_PLATE	安全プレート	(1)
42		SM-4040655-SP	SCREW M4 L=6	なべ小ねじ M4 L=6	(2)
43		400-06836	OIL_TANK_ASM.	オイルタンク組	2
44		SM-6040650-TP	SCREW	平ねじ M4 L=6	2
45		400-06840	RUBBER_BUSH	止栓	4
46		141-13468	BOBBIN_THREAD_TENSION_ASM.	糸巻き糸調子(組)	1
47		110-72402	THREAD_TENSION_NUT	第一糸調子ナット	(1)
48		NS-6110310-SP	NUT 11/64-40	六角ナット 11/64-40	(1)
49		141-13450	BOBBIN_THREAD_TENSION_ROD_ASM.	糸巻き糸調子棒(結合)	(1)
50		B3126-012-000	THREAD_TENSION_DISK	糸調子皿	(2)
51		D7133-555-B00	CONNECTING_ROD_SPRING	下連結棒ばね	(1)
52		WS-0451040-KP	SPRING_WASHER 4.5X8.5X1	ばね座金 4.5 X 8.5 X 1	1
53	*	B1114-280-000	PIN	ピン	1

2. FRAME & MISCELLANEOUS COVER COMPONENTS (2)

頭部・外装関係 (2)

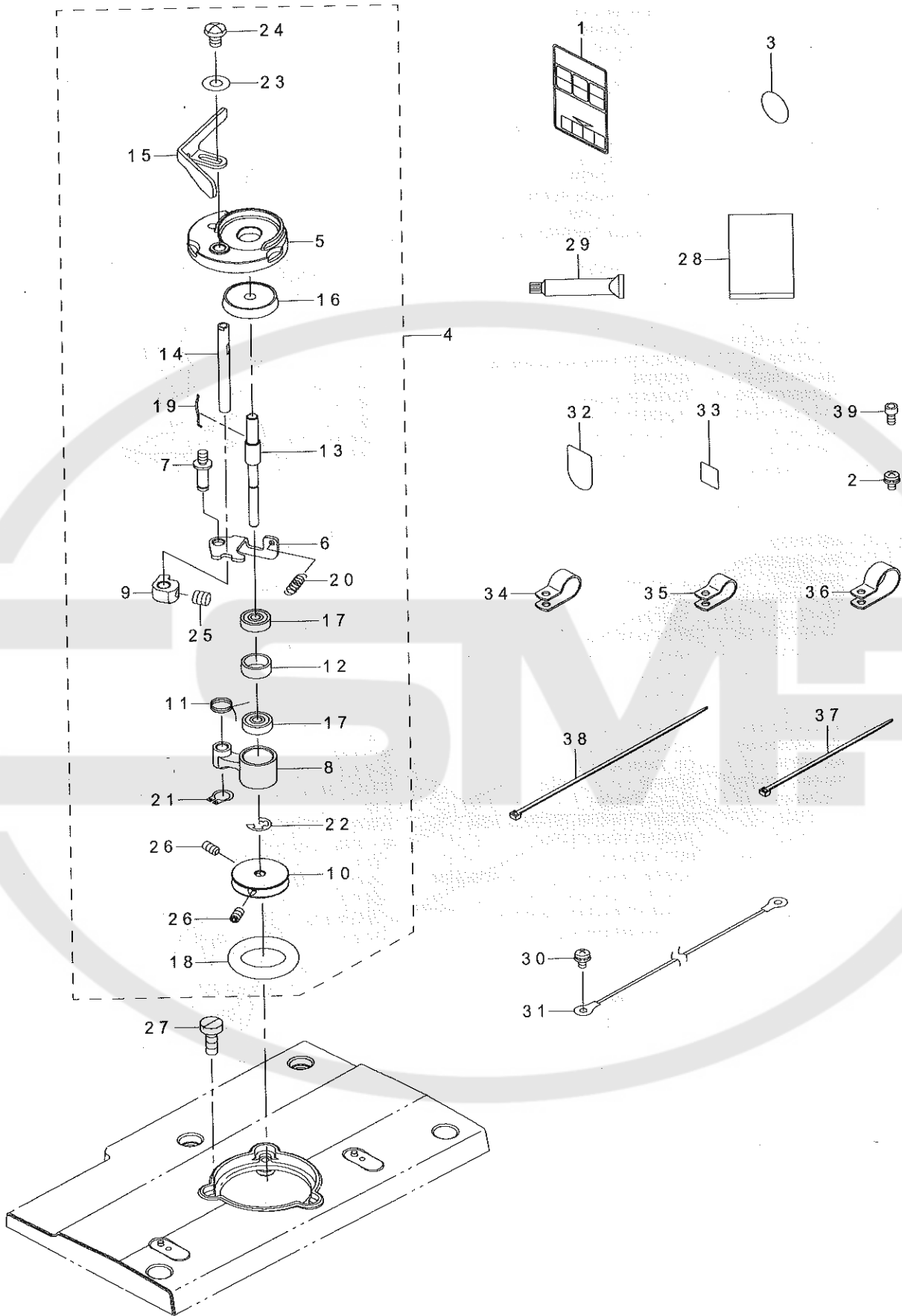

REF.NO	NOTE	PART NO	DESCRIPTION	品名	Qty
1		CM-3012000-01	SAFETY LABEL_S	頭部注意安全シール(小)	2
2		SL-4040891-SC	SCREW M4 L=8	座金付きなべ小ねじ M4 L=8	12
3		229-01805	GROUND MARK	グランドマーク	1
4		400-28338	BOBBIN_WINDER_UNIT	糸巻き装置組	1
5		262-60109	BTW_BASE	糸巻き取付台	(1)
6		262-60208	BTW_CAM_PLATE	糸巻き調節板	(1)
7		262-60307	BTW_BASE_SHAFT	糸巻き調節板軸	(1)
8		262-60406	BTW_SHAFT_BASE	糸巻き腕	(1)
9		262-60505	BTW_CAM_LEVER	糸巻きカム	(1)
10		262-60604	BTW_WHEEL	糸巻き車	(1)
11		262-60703	BTW_TORSION_SPRING	糸巻き腕ばね	(1)
12		262-60802	BTW_BEARING_SPACER	ベアリングスペーサー	(1)
13		400-23865	BTW_SHAFT	糸巻き軸	(1)
14		400-23866	BTW_LEVER_SHAFT	糸巻きキレバ軸	(1)
15		400-30829	BTW_LEVER	糸巻きレバー	(1)
16		262-61206	BTW_SPACER	ボビン座	(1)
17		262-61305	BTW_BEARING	糸巻き軸ベアリング	(2)
18 ☆		262-61503	BTW_WHEEL_RUBBER	糸巻き摩擦車	(1)
19 ☆		262-61602	BOBBIN_SPRING	ボビン止めばね	(1)
20		262-61701	BTW_SPRING	糸巻き調節板戻しばね	(1)
21		RC-0560711-KP	RETAINING RING	C形止め輪	(1)
22		RE-0400000-K0	E-RING 4	E形止め輪 4	(1)
23		WP-0450826-SC	WASHER 4.5X10X0.8	平座金 4.5 X 10 X 0.8	(1)
24		SM-5040655-SN	SCREW	パインドねじ	(1)
25		SM-8050502-TP	SCREW M5 L=5	止めねじ	(1)
26		SM-8040802-TP	SCREW M4X8	止めねじ M4 X 0.7 L=8	(2)
27		SM-6041150-TP	SCREW	平ねじ M4 L=11	3
28		400-31336	FLAT_BAG	ポリエチレン袋	1
29 ☆		400-13640	JUKI_GREASE_B_TUBE	JUKI グリース B	1
30		SL-4040891-SC	SCREW M4 L=8	座金付きなべ小ねじ M4 L=8	1
31		141-15554	HEAD GROUND CABLE A ASM.	頭部アースケーブル A 組	1
32		CM-1001000-01	OIL INJECTION PROHIBITION LABEL	油注入禁止ラベル	1
33	#01	CM-6001001-01	WEEE MARK LABEL S	WEEE マーク ラベル S	1
34		HX-0015000-0F	CABLE CLIP	ケーブルクリップ	4
35		HX-0015000-0D	CABLE CLIP	ケーブルクリップ	10
36		HX-0015000-0H	CABLE CLIP	ケーブルクリップ	3
37		EA-9500B01-00	CABLE BAND	束線バンド	3
38		EA-9500B02-00	CABLE BAND 150	結束バンド 150	5
39		SM-6040802-TP	SCREW M4X0.7 L=8	六角穴ボルト	5
		NOTE(注記)	#01...FOR JE	JE 用	

3. FRAME & MISCELLANEOUS COVER COMPONENTS (3)(FOR 4530)

頭部・外装関係 (3) (4530用)

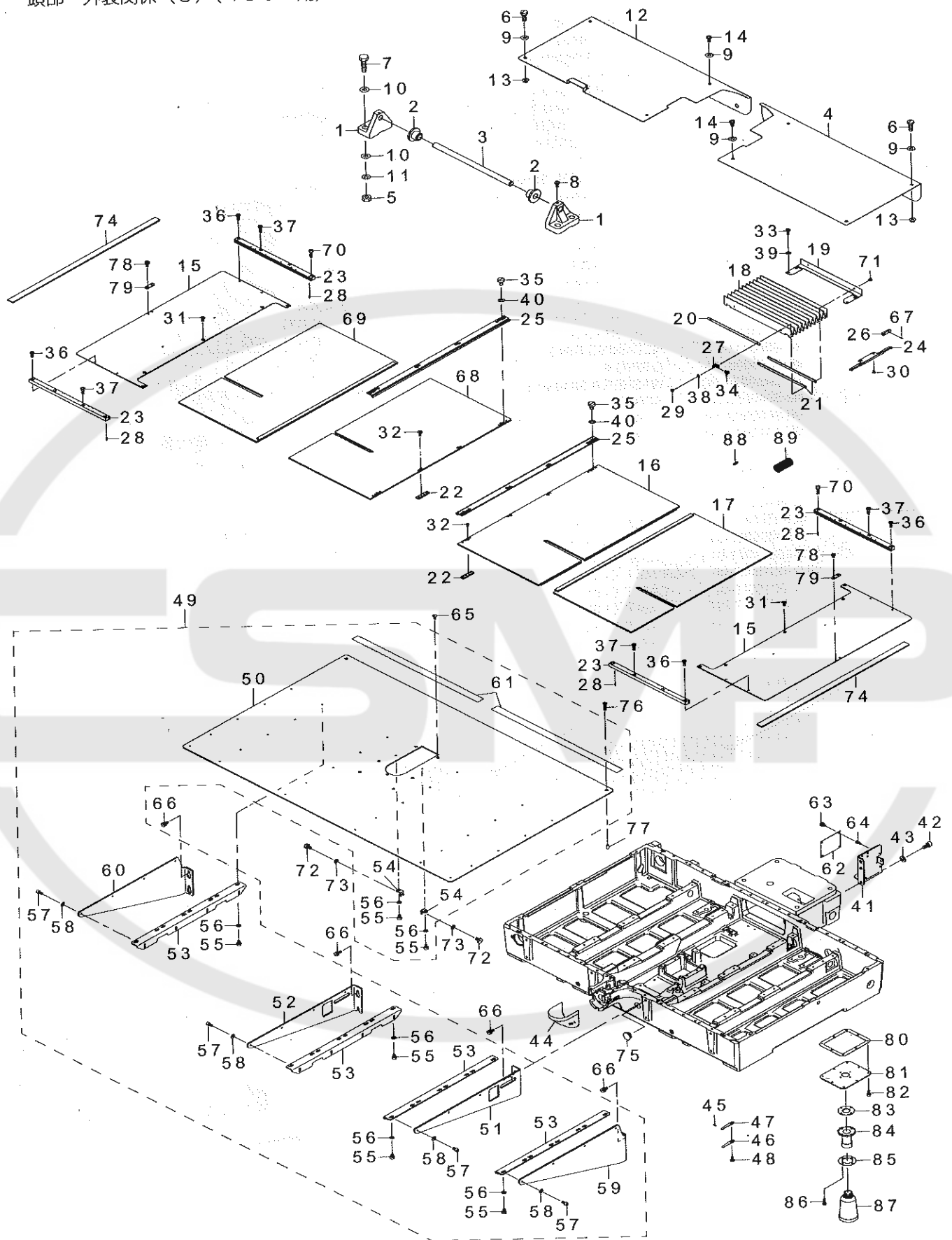

REF.NO	NOTE	PART NO	DESCRIPTION	品名	Qty
1		B1111-220-000-A	BED HINGE	ベッドヒンジ	2
2		B1115-220-000	RUBBER PAD A	防振ゴム A	2
3		B1120-223-C00	HING SHAFT	ベッドヒンジ軸	1
4		400-72073	BED COVER RIGHT	ベッドカバー右	1
5		NM-6120011-SF	NUT M12	六角ナット M12 1種	4
6		SM-4055001-SF	SCREW M5 L=50	なべねじ M5 X 0.8 L=50	4
7		SM-9124503-SB	SCREW M12 L=45	六角ボルト M12 L=45	4
8		SS-9151240-SN	SCREW 15/64-28 L=11.5	六角ボルト 15/64-28	2
9		WP-0561616-SC	WASHER 5.6X16X1.6	平座金 5.6 X 16 X 1.6	8
10		WP-1302501-SE	WASHER M12	平座金	8
11		WS-1253010-KN	SPRING WASHER 12.5X21.5X3	ばね座金 12.5 X 21.5 X 3	4
12		400-72074	BED COVER LEFT	ベッドカバー左	1
13		NM-3050610-SF	NUT	フランジ付きナット	4
14		SM-4051001-SN	SCREW M5	なべ小ねじ M5 X 0.8 L=10	4
15		400-72076	FEED BASE COVER 4530	送り台カバー4530	2
16		400-72191	X_FEED_UPPER_COVER_R_ASM_4530	X 移動上カバー右組4530	2
17		400-72184	X_FEED_LOWER_COVER_R_ASM_4530	X 移動下カバー右組4530	2
18		400-72174	FEED COVER	移動カバー (ジャバラ)	1
19		400-72081	FEED COVER STAY	移動カバーステー	1
20		400-72079	FEED COVER FIX PLATE A	移動カバー固定板 A	1
21		400-72080	FEED COVER FIX PLATE B	移動カバー固定板 B	2
22		400-72195	FEED_COVER_RALL_STOPPER_PLATE	補助カバーレール止め板	8
23		400-72143	FEED BASE SUPPORT COVER RALL X	送り台補助カバーレール X	8
24		B1182-223-C00	RAIL GUIDE	補助カバーレールガイド	2
25		400-72078	FEED BASE SUPPORT COVER RALL Y	送り台補助カバーレール Y	2
26		B1193-223-C00	GUIDE RAIL CLICK	ガイドレールバ	4
27		B1157-215-000	MOVEMENT COVER PLATE	移動カバー取付板	2
28		PS-0250062-KH	SPRING PIN 2.5X6	スプリングピン 2.5 X 6	8
29		SM-4030401-SC	SCREW M3X0.5 L=4	なべ小ねじ M3 X 0.5 L=4	2
30		SM-1040870-TP	SCREW	皿小ねじ M4 L=8	4
31		SM-1040801-SP	SCREW M4X0.7 L=8	皿小ねじ M4 X 0.7 L=8	10
32		SM-1030601-SP	SCREW M3 L=6	皿ねじ M3 L=6	8
33	*	SM-4041055-SP	SCREW	なべねじ M4 L=10	4
34		SM-4040655-SP	SCREW M4 L=6	なべ小ねじ M4 L=6	2
35		SM-6040650-TP	SCREW	平ねじ M4 L=6	8
36		SM-4041001-SC	SCREW M4X0.7 L=10	なべ小ねじ M4 X 0.7 L=10	4
37		SM-4041401-SC	SCREW M4X0.7 L=14	なべ小ねじ M4 X 0.7 L=14	12
38		WP-0330501-SB	WASHER M3	平座金みがき丸 M3	2
39		WP-0450801-SD	WASHER 4.5X10X0.8	平座金 4.5 X 10 X 0.8	4
40		WP-0450000-SD	WASHER 4.5X8X0.5	平座金 4.5 X 8 X 0.5	8
41		400-24997	LIFTER_BASE	INT 基板取付板	1
42		SM-6061202-TP	SCREW M6 L=12	六角穴ボルト M6 L=12	2
43		WP-0641601-SC	WASHER	平座金みがき丸 M6	2
44		138-16855	CYLINDER ARM CAP	釜カバー組	1
45		312-62801	PIN	移動針受け固定ピン	1
46		262-21200	HOOK COVER PRESSER SPRING B	釜カバー押えばね (B)	1
47		262-21101	HOOK COVER PRESSER SPRING A	釜カバー押えばね (A)	1
48		SL-4041091-SC	SCREW M4 L=10	なべ小ねじセムス M4 X 0.7 L=10	1
49		400-72244	NEEDLE PLATE SUPPORT COVER ASM	針板補助カバー組 4530	1
50		400-72084	NEEDLE PLATE SUPPORT COVER(4530)	針板補助カバー (4530)	(1)
51		400-72176	COVER_SUPPORT_A_RIGHT	針板補助カバー支え A 右	(2)
52		400-72175	COVER_SUPPORT_A_LEFT	針板補助カバー支え A 左	(2)
53		400-72179	COVER_SUPPORT_BRACKET	針板補助カバー台	(6)
54		400-25014	COVER_SUPPORT_B	針板補助カバー支え B	(2)
55		SM-6450610-TP	SCREW	平小ねじ M4 X 0.5 L=6	(32)
56		WP-0450801-SP	WASHER	平座金	(32)
57		SM-6040802-TP	SCREW M4X0.7 L=8	六角穴ボルト	(24)
58		WP-0450801-SP	WASHER	平座金	(24)
59		400-72178	COVER_SUPPORT_B_RIGHT	針板補助カバー支え B 右	(1)
60		400-72177	COVER_SUPPORT_B_LEFT	針板補助カバー支え B 左	(1)
61		400-51501	TAPE	摺動テープ	(2)
62		400-40230	INT PCB ASM	INT 基板組	1
63		SL-4040891-SC	SCREW M4 L=8	座金付きなべ小ねじ M4 L=8	4
64		HX-0033900-00	STUD	基板パーツ	4
65		SM-1040870-TP	SCREW	皿小ねじ M4 L=8	2
66	*	SL-9061600-SF	SCREW	座金付き六角穴ボルト	12
67		PS-0150065-KP	SPRING PIN 1.5X6	スプリングピン 1.5 X 6	8
68		400-72193	X_FEED_UPPER_COVER_L_ASM_4530	X 移動上カバー左組4530	1
69		400-72186	X_FEED_LOWER_COVER_L_ASM_4530	X 移動下カバー左組4530	1
70		SM-6041402-TN	SCREW M4X0.7 L=14	六角穴ボルト M4 X 0.7 L=14	2
71		SM-7030450-SC	SCREW M3X0.5 L=4	丸平小ねじ M3 X 0.5 L=3.5	2
72		SM-6050802-TP	SCREW M5X0.8 L=8	六角穴ボルト M5 X 0.7 L=8	2
73	*	WP-0520656-SA	WASHER 5.2X9.5X0.6	平座金 5.2 X 9.5 X 0.6	2
74		G6113-875-00A	CLOTH PRESSER SPONGE A	布押えスポンジ A	1
75		TA-2100904-R0	RUBBER PLUG	止栓	1
76		SM-1041601-SC	SCREW M4X0.7 L=16	皿小ねじ M4 X 0.7 L=16	2
77		122-09706	COLLAR	副送りリンクカラー	2
78	*	SL-4041091-SC	SCREW M4 L=10	なべ小ねじセムス M4 X 0.7 L=10	4
79		400-72214	FEED COVER STOPPER	移動カバーストッパー	2
80		400-72213	OIL_PAN_GASKET	パッキン	1
81		400-72212	OIL_PAN	オイルパン	1
82		SM-6040802-TP	SCREW M4X0.7 L=8	六角穴ボルト	8
83		B8112-220-000	OIL SEAL	油抜きオイルシール	1
84		B8202-205-000	OIL MANAGEMENT	油抜き	1
85		B8111-220-000	WASHER	油抜き座金	1
86		SL-4031481-SC	SCREW M3 X 14	なべ小ねじセムス M3 X 0.5 L=14	4
87		B9121-012-000	OIL CAN	油びん	1
88	*	400-82017	X_FEED_LOWER_COVER_STOPPER_G	X 移動下カバーストッパーゴム	4
89	*	HX-0030700-0D	CABLE PARTS	束線パーツ	0.05

4. FRAME & MISCELLANEOUS COVER COMPONENTS (4)(FOR 6030)

頭部・外装関係 (4) (6030用)

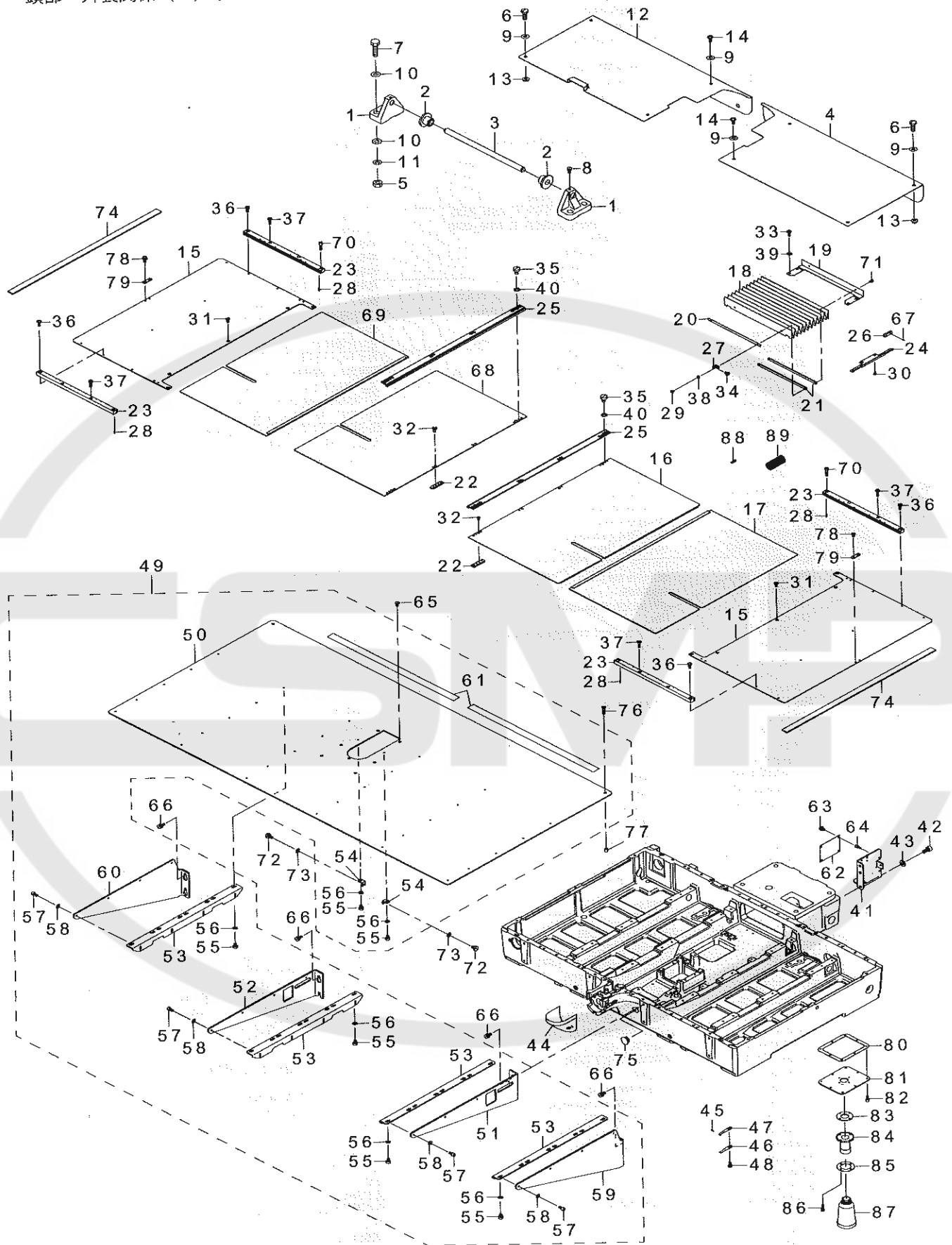

REF.NO	NOTE	PART NO	DESCRIPTION	品名	Qty
1		B1111-220-000-A	BED HINGE	ベッドヒンジ	2
2		B1115-220-000	RUBBER PAD A	防振ゴム A	2
3		B1120-223-C00	HING SHAFT	ベッドヒンジ軸	1
4		400-72073	BED COVER RIGHT	ベッドカバー右	1
5		NM-6120011-SF	NUT M12	六角ナット M12 1種	4
6		SM-4055001-SF	SCREW M5 L=50	なべねじ M5 X 0.8 L=50	4
7		SM-9124503-SB	SCREW M12 L=45	六角ボルト M12 L=45	4
8		SS-9151240-SN	SCREW 15/64-28 L=11.5	六角ボルト 15/64-28	2
9		WP-0561616-SC	WASHER 5.6X16X1.6	平座金 5.6 X 16 X 1.6	8
10		WP-1302501-SE	WASHER M12	平座金	8
11		WS-1253010-KN	SPRING WASHER 12.5X21.5X3	ばね座金 12.5 X 21.5 X 3	4
12		400-72074	BED COVER LEFT	ベッドカバー左	1
13		NM-3050610-SF	NUT	フランジ付きナット	4
14		SM-4051001-SN	SCREW M5	なべねじ M5 X 0.8 L=10	4
15		400-72075	FEED BASE COVER 6030	送り台カバー 6030	2
16		400-72187	X_FEED_UPPER_COVER_R_ASM_6030	X 移動上カバー右組 6030	2
17		400-72180	X_FEED_LOWER_COVER_R_ASM_6030	X 移動下カバー右組 6030	2
18		400-72174	FEED COVER	移動カバー (ジャバラ)	1
19		400-72081	FEED COVER STAY	移動カバーステー	1
20		400-72079	FEED COVER FIX PLATE A	移動カバー固定板 A	1
21		400-72080	FEED COVER FIX PLATE B	移動カバー固定板 B	2
22		400-72195	FEED_COVER_RALL_STOPPER_PLATE	補助カバーレール止め板	8
23		400-72143	FEED BASE SUPPORT COVER RALL X	送り台補助カバーレール X	10
24		B1182-223-C00	RAIL GUIDE	補助カバーレールガイド	2
25		400-72078	FEED BASE SUPPORT COVER RALL Y	送り台補助カバーレール Y	2
26		B1193-223-C00	GUIDE RAIL CLICK	ガイドレール爪	4
27		B1157-215-000	MOVEMENT COVER PLATE	移動カバー取付板	2
28		PS-0250062-KH	SPRING PIN 2.5X6	スプリングピン 2.5 X 6	8
29		SM-4030401-SC	SCREW M3X0.5 L=4	なべねじ M3 X 0.5 L=4	2
30		SM-1040870-TP	SCREW	皿ねじ M4 L=8	4
31		SM-1040801-SP	SCREW M4X0.7 L=8	皿ねじ M4 X 0.7 L=8	10
32		SM-1030601-SP	SCREW M3 L=6	皿ねじ M3 L=6	8
33	*	SM-4041055-SP	SCREW	なべねじ M4 L=10	4
34		SM-4040655-SP	SCREW M4 L=6	なべねじ M4 L=6	2
35		SM-6040650-TP	SCREW	平ねじ M4 L=6	8
36		SM-4041001-SC	SCREW M4X0.7 L=10	なべねじ M4 X 0.7 L=10	4
37		SM-4041401-SC	SCREW M4X0.7 L=14	なべねじ M4 X 0.7 L=14	12
38		WP-0330501-SB	WASHER M3	平座金みがき丸 M3	2
39		WP-0450801-SD	WASHER 4.5X10X0.8	平座金 4.5 X 10 X 0.8	4
40		WP-0450000-SD	WASHER 4.5X8X0.5	平座金 4.5 X 8 X 0.5	8
41		400-24997	LIFTER BASE	INT 基板取付板	1
42		SM-6061202-TP	SCREW M6 L=12	六角穴ボルト M6 L=12	2
43		WP-0641601-SC	WASHER	平座金みがき丸 M6	2
44		138-16855	CYLINDER ARM CAP	釜カバー組	1
45		312-62801	PIN	移動針受け固定ピン	1
46		262-21200	HOOK COVER PRESSER SPRING B	釜カバー押えばね (B)	1
47		262-21101	HOOK COVER PRESSER SPRING A	釜カバー押えばね (A)	1
48		SL-4041091-SC	SCREW M4 L=10	なべねじ M4 X 0.7 L=10	1
49		400-72245	NEEDLE PLATE SUPPORT COVER ASM	針板補助カバー組 6030	1
50		400-72085	NEEDLE PLATE SUPPORT COVER 6030	針板補助カバー 6030	(1)
51		400-72176	COVER_SUPPORT_A_RIGHT	針板補助カバー支え A 右	(2)
52		400-72175	COVER_SUPPORT_A_LEFT	針板補助カバー支え A 左	(2)
53		400-72179	COVER_SUPPORT_BRACKET	針板補助カバー台	(6)
54		400-25014	COVER_SUPPORT_B	針板補助カバー支え B	(2)
55		SM-6450810-TP	SCREW	平小ねじ M4 X 0.5 L=6	(32)
56		WP-0450801-SP	WASHER	平座金	(32)
57		SM-6040802-TP	SCREW M4X0.7 L=8	六角穴ボルト	(24)
58		WP-0450801-SP	WASHER	平座金	(24)
59		400-72178	COVER_SUPPORT_B_RIGHT	針板補助カバー支え B 右	(1)
60		400-72177	COVER_SUPPORT_B_LEFT	針板補助カバー支え B 左	(1)
61		400-51501	TAPE	摺動テープ	(2)
62		400-40230	INT PCB ASM	INT 基板組	1
63		SL-4040891-SC	SCREW M4 L=8	座金付きなべねじ M4 L=8	4
64		HX-0033900-00	STUD	基板パーツ	4
65		SM-1040870-TP	SCREW	皿ねじ M4 L=8	2
66	*	SL-9061600-SF	SCREW	座金付き六角穴ボルト	12
67		PS-0150065-KP	SPRING PIN 1.5X6	スプリングピン 1.5 X 6	8
68		400-72189	X_FEED_UPPER_COVER_L_ASM_6030	X 移動上カバー左組 6030	1
69		400-72183	X_FEED_LOWER_COVER_L_ASM_6030	X 移動下カバー左組 6030	1
70		SM-6041402-TN	SCREW M4X0.7 L=14	六角穴ボルト M4 X 0.7 L=14	2
71		SM-7030450-SC	SCREW M3X0.5 L=4	丸平ねじ M3 X 0.5 L=3.5	2
72		SM-6050802-TP	SCREW M5X0.8 L=8	六角穴ボルト M5 X 0.7 L=8	2
73	*	WP-0520656-SA	WASHER 5.2X9.5X0.6	平座金 5.2 X 9.5 X 0.6	2
74		G6113-875-00A	CLOTH PRESSER SPONGE A	布押えスポンジ A	1
75		TA-2100904-R0	RUBBER PLUG	止栓	1
76		SM-1041601-SC	SCREW M4X0.7 L=16	皿ねじ M4 X 0.7 L=16	2
77		122-09706	COLLAR	副送りリンクカラー	2
78	*	SL-4041091-SC	SCREW M4 L=10	なべねじ M4 X 0.7 L=10	4
79		400-72214	FEED COVER STOPPER	移動カバーステー	2
80		400-72213	OIL_PAN_GASKET	パッキン	1
81		400-72212	OIL_PAN	オイルパン	1
82		SM-6040802-TP	SCREW M4X0.7 L=8	六角穴ボルト	8
83		B8112-220-000	OIL SEAL	油抜きオイルシール	1
84		B8202-205-000	OIL MANAGEMENT	油抜き	1
85		B8111-220-000	WASHER	油抜き座金	1
86		SL-4031481-SC	SCREW M3 X 14	なべねじ M3 X 0.5 L=14	4
87		B9121-012-000	OIL CAN	油びん	1
88	*	400-82017	X_FEED_LOWER_COVER_STOPPER_G	X 移動下カバーステー	4
89	*	HX-0030700-0D	CABLE PARTS	束線パーツ	0.05

5. MAM SHAFT & NEEDLE BAR COMPONENTS

上軸・針棒関係

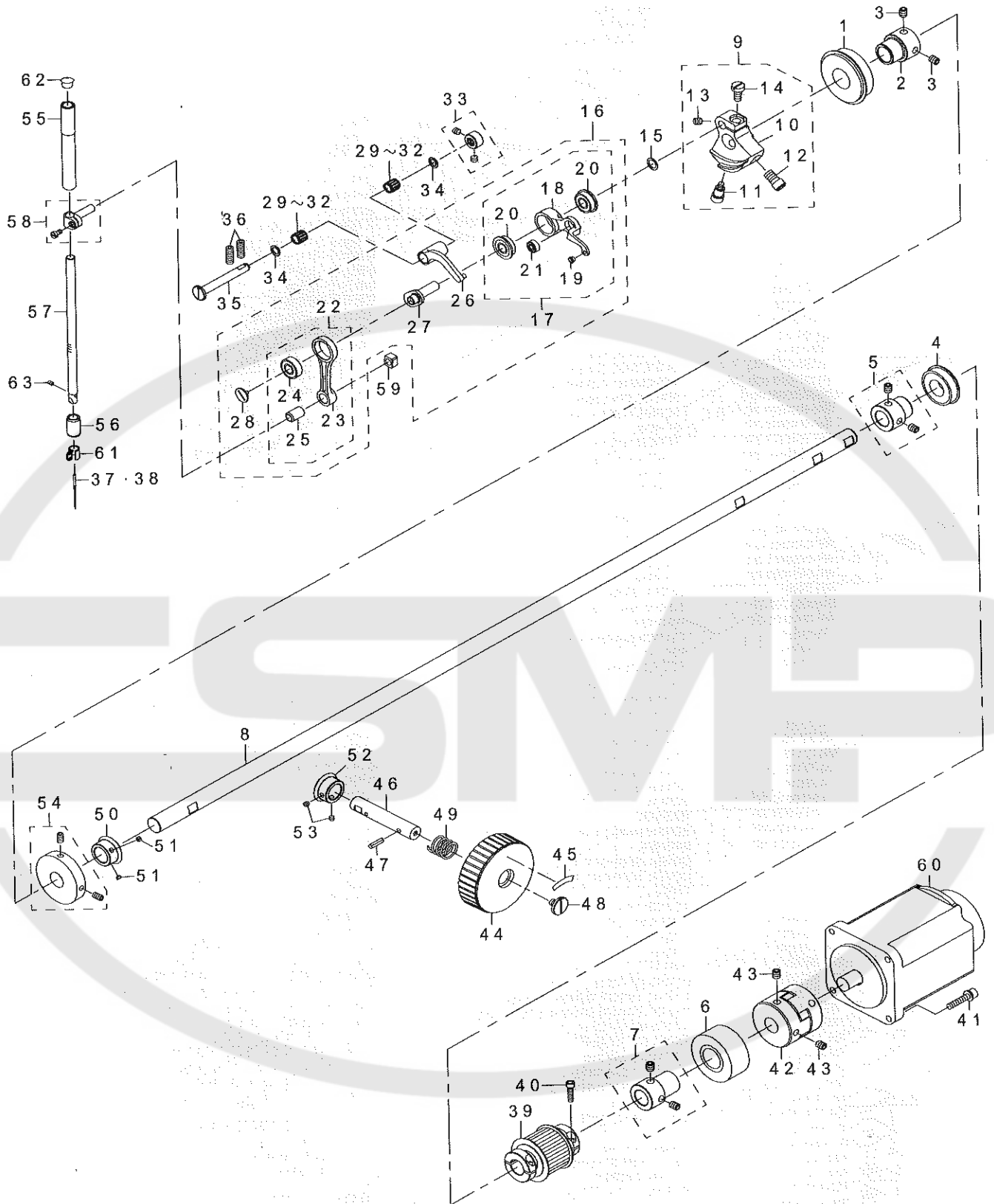

REF.NO	NOTE	PART NO	DESCRIPTION	品名	Qty	
1		SB-1200009-00	BEARING	ころがり軸受	1	
2		236-04200	MAIN SHAFT BEARING SUPPORT	上軸ベアリング受	1	
3		SM-8060812-TP	SCREW M6 L=8	止めねじ M6 L=8	2	
4		SB-1200018-00	BEARING	ころがり軸受	1	
5		400-10415	BEARING_BUSH_A_ASM.	上軸ベアリングブッシュ組	1	
6		SB-1200017-00	BEARING	ころがり軸受	1	
7		400-10418	BEARING_BUSH_B_ASM.	後ろメタルベアリングブッシュ組	1	
8		400-72086	MAIN SHAFT	上軸	1	
9		400-10422	COUNTER_WEIGHT_ASM.	釣合錘組	1	
10		400-10423	COUNTER_WEIGHT	釣合錘	(1)	
11		400-10424	COUNTER_WEIGHT_SCREW_A	釣合錘止めねじ A	(1)	
12		400-10425	COUNTER_WEIGHT_SCREW_B	釣合錘止めねじ B	(1)	
13		400-10426	COUNTER_WEIGHT_SCREW_C	釣合錘止めねじ C	(1)	
14		400-10427	COUNTER_WEIGHT_SCREW_D	釣合錘止めねじ D	(1)	
15		WP-0820516-SP	WASHER 11.6X8.2X0.6	平座金 8.2 X 11.6 X 0.6	1	
16		400-06529	THREAD TAKE UP COMPL.	リンク天秤結合	1	
17		400-06530	THREAD TAKE UP LEVER_ASM.	天秤組	(1)	
18		400-06531	THREAD TAKE UP LEVER	天秤	(1)	
19		B1908-505-000	THREAD PASS BUSH	天秤糸道ブッシュ	(1)	
20		SB-1080022-00	BEARING	ころがり軸受	(2)	
21		SB-1040016-00	BEARING	ころがり軸受	(1)	
22		400-06534	NEEDLE_BAR_CRANK_ROD_ASM.	ハリボウ克蘭クロッド組	(1)	
23		400-06535	NEEDLE_BAR_CRANK_ROD	ハリボウ克蘭クロッド	(1)	
24		SB-1080023-00	BEARING	ころがり軸受	(1)	
25		228-91006	NEEDLE BAR CRANK ROD BUSH	針棒克蘭クロッドブッシュ	(1)	
26		400-06532	THREAD TAKE UP CRANK	天秤克蘭ク	(1)	
27		400-06537	NEEDLE ROD_CRANK	針棒克蘭ク	(1)	
28		B1903-552-000	LEFT SCREW	左ねじ	(1)	
29	#01	SB-3070002-0A	BEARING	ころがり軸受	2	
30	#01	SB-3070002-0B	BEARING	ころがり軸受	2	
31	#01	SB-3070002-0C	BEARING	ころがり軸受	2	
32	#01	SB-3070002-0D	BEARING	ころがり軸受	2	
33		400-10434	THRUST COLLAR_ASM.	天秤克蘭クピンスラストカラー組	1	
34		228-91204	BEARING SUPPORT	ベアリング押え	2	
35		400-11902	THREAD TAKE UP CRANK SHAFT	天秤克蘭ク軸	1	
36		SM-8061612-TP	SCREW M6X16	止めねじ M6 L=16	2	
37	☆	#02	MDP-170B1800	NEEDLE DPX17 #18	針 DPX 17 #18	1
38	☆	#03	MC-3720011-00	NEEDLE 135X17 #110	針 SY 3355 110	1
39		400-72233	SPROCKET_ASM	上軸スプロケット組	1	
40		SM-6041602-TP	SCREW M4X0.7 L=16	六角穴ボルト M4 X 0.7 L=16	4	
41		SL-6052592-TN	BOLT	座金付き六角穴ボルト	4	
42		236-04309	COUPLING	カップリング	1	
43		SM-8060812-TP	SCREW M6 L=8	止めねじ M6 L=8	4	
44		B1212-210-D00	PULLEY	手元プーリ	1	
45		B1144-210-000	REVOLVING DIRECTION LABEL	回転方向ラベル	1	
46		B1213-210-D00	PULLEY SHAFT	手元プーリ軸	1	
47		PS-0400142-KH	SPRING PIN 4X14	スプリングピン 4 X 14	1	
48		A1230-500-000-A	HANDWHEEL SETSCREW	はずみ車止めねじ	1	
49		GAF-01007000	SPRING	送り固定ばね	1	
50		400-06515	GEAR_A	手元プーリーギア A	1	
51		SM-8040310-SS	SCREW M4 L=3	止めねじ	2	
52		400-06516	GEAR_B	手元プーリーギア B	1	
53		SM-8040310-SS	SCREW M4 L=3	止めねじ	2	
54		400-10533	BTW_DRIVING_WHEEL_ASM.	糸巻き駆動車組	1	
55		400-10441	NEEDLE_ROD_METAL	針棒上メタル	1	
56		400-10442	NEEDLE_ROD_LOWER_METAL	針棒下メタル	1	
57		400-26882	NEEDLE_BAR	針棒	1	
58		B1411-552-0A0	NEEDLE BAR CONNECTING ASM.	針棒抱き組	1	
59		B1414-555-000	SLIDE BLOCK	針棒抱き案内コ口	1	
60		400-52937	550W_SERVO_MOTOR	550W サーボモータ	1	
61	#04	400-26884	NEEDLE_BAR_SHREAD_GUIDE_H	針棒系案内 厚物	1	
62		229-01409	NEEDLE BAR UPPER BUSH CAP	針棒上メタルキャップ	1	
63		SM-8030412-TP	SCREW	止めねじ M3 L=4	1	

NOTE(注記)

#01...SELECTIVE PARTS
 #02...TYPE H(FOR ST)
 #03...TYPE H(FOR JE)
 #04...TYPE H

選択部品
 H 仕様 (ST 用)
 H 仕様 (JE 用)
 H 仕様

6. PRESSER MECHANISM & PRESSER VARIABLE COMPONENTS (1)

中押え・中押え可変関係 (1)

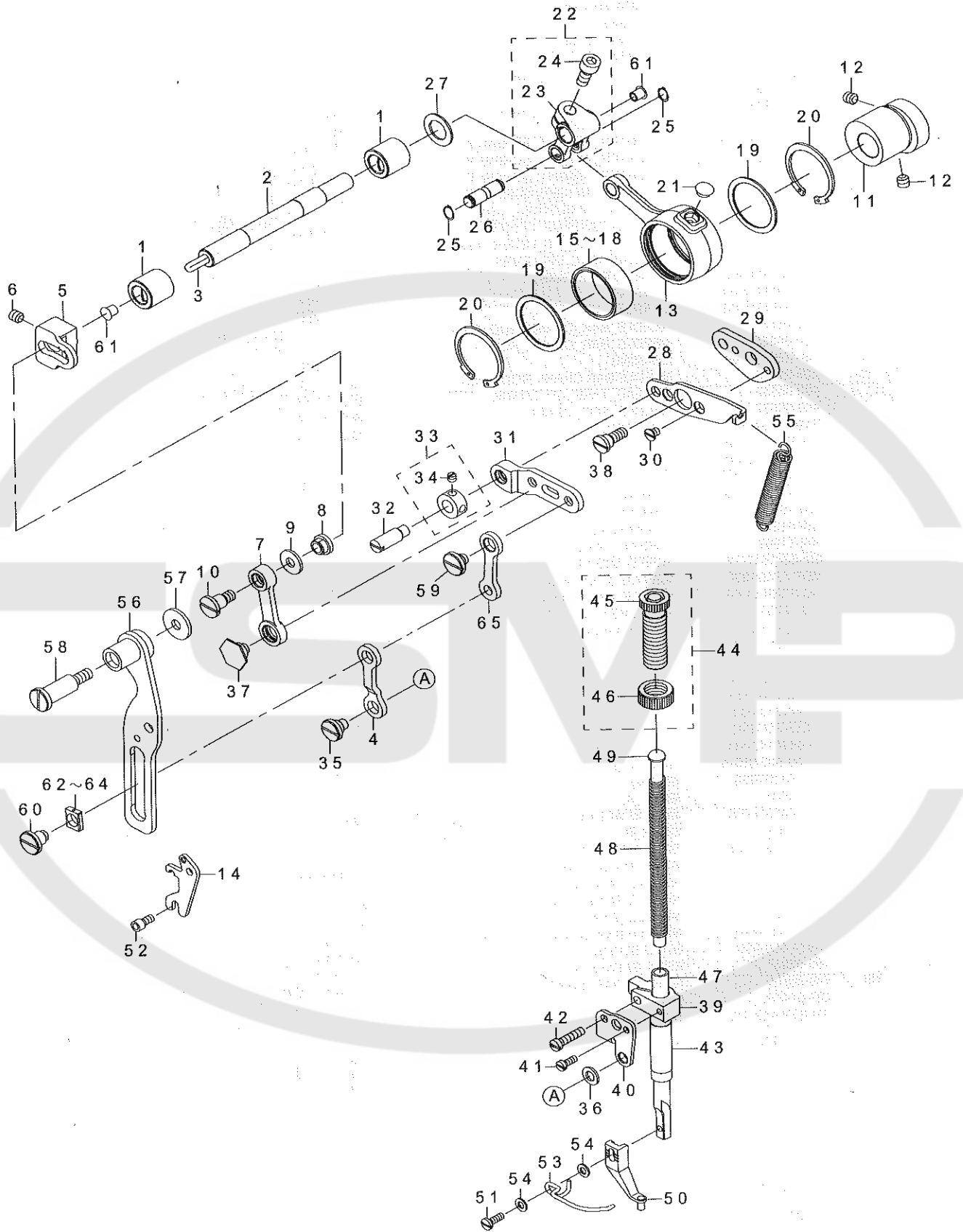

REF.NO	NOTE	PART NO	DESCRIPTION	品名	Qty
1		400-25431	BUSHING	メタル	2
2		400-25427	INTERMEDIATE_PRESSER_SHAFT	中押え揺動軸	1
3		CQ-3030000-00	OIL WICK	油芯	0.18
4		400-30617	INTERMEDIATE_PRESSER_LINK_D	中押えリンク D	1
5		400-25012	ADJUSTING_ARM	中押え調節腕	1
6		SM-8060812-TP	SCREW M6 L=8	止めねじ M6 L=8	1
7		400-68835	INTERMEDIATE_PRESSURE_LINK	中押えリンク	1
8		400-25415	ADJUSTING_NUT	中押え調節ナット	1
9		WP-0611626-SP	WASHER 15X6X1.6	平座金	1
10		SD-0800746-TP	SHOULDER SCREW	段ねじ D=8 H=7.4	1
11		400-25428	ECCENTRIC_CAM	中押え偏芯カム	1
12		SM-8060812-TP	SCREW M6 L=8	止めねじ M6 L=8	2
13		400-25011	CRANK_CONNECTING_ROD	中押えカムロッド	1
14		400-68833	POSITIONING_LINK_SPRING_HOOK	位置決めリンクばね掛け	1
15	#01	B1636-581-A00	NEEDLE BEARING A	ニードル ベアリング A	1
16	#01	B1636-581-B00	NEEDLE BEARING B	ニードル ベアリング B	1
17	#01	B1636-581-C00	NEEDLE BEARING	ニードル ベアリング	1
18	#01	B1636-581-D00	NEEDLE BEARING	ニードル ベアリング	1
19		400-12965	BEARING_SUPPORT_PLATE	ベアリング板	2
20		RC-3781518-KP	RETAINING RING	C 形止め輪	2
21		TA-0750404-R0	PLUG D=7.5 L=3.5	止栓 D=7.5 L=3.5	1
22		131-22452	FEED BRANCH CRANK ASM.	送り二股クランク組	1
23		131-22403	FEED BRANCH CRANK	送り二股クランク	(1)
24		SM-6061402-TP	SCREW M6 L=14	六角穴ねじ M6 L=14	(1)
25		RC-0650811-KP	RETAINING RING	C 形止め輪	2
26		400-25429	ROD_CONNECTING_SHAFT	中押えロッド連結軸	1
27		WP-1221016-SP	WASHER	平座金	1
28		400-68834	POSITIONING_LINK	位置決めリンク	1
29		400-24988	POSITIONING_LINK_B	中押え位置決めリンク B	1
30		SS-1110640-TP	SCREW 11/64-40 L=5.5	皿ねじ 11/64-40 L=5.5	2
31		400-30620	INTERMEDIATE_PRESSER_LINK_B	中押えリンク B	1
32		B1408-180-000	HINGE SCREW	針棒上下リンクピン	1
33		CS-079073A-SH	THRUST COLLAR ASM.	スラスト受け組	1
34		SS-8110410-TP	SCREW 11/64-40 L=3.5	止めねじ 11/64-40 L=3.5	(2)
35		SD-0800386-TP	SHOULDER SCREW D=8 H=3.75	段ねじ D=8 H=3.75	1
36		400-29419	LINK_CONNECTING_PLATE_WASHER	中押えリンク中継板座金	1
37		SD-1000506-TP	SHOULDER SCREW D=10 H=4.95	段ねじ D=10 H=4.95	1
38		SD-0800408-TP	SHOULDER SCREW	段ねじ D=8 H=4	1
39		236-10108	PRESSER BAR GUIDE BRACKET	押え棒抱き	1
40		400-24991	LINK_CONNECTING_PLATE	中押えリンク中継板	1
41		SS-6090910-SP	SCREW 9/64-40 L=9	平ねじ 9/64-40 L=9	1
42		SS-7111810-TP	SCREW 11/64-40 L=18	丸平ねじ 11/64-40 L=18	1
43		400-32798	PRESSER_BUSHING	中押え下メタル	1
44		229-07554	PRESSER SPRING REG NUT ASM.	送り調節ねじナット組	1
45		229-07505	PRESSER SPRING REGULATOR	押え調節ねじ	(1)
46		229-07604	PRESSER SPRING REGULATOR NUT	押え調節ねじナット	(1)
47		400-30623	INTERMEDIATE_PRESSER_BAR	中押え棒	1
48		B1611-210-00A	INNER PRESSER SPRING	中押えばね	1
49		400-23631	PRESSER GUIDE BAR	中押え案内棒	1
50	☆	400-23632	INTERMEDIATE PRESSER A	中押え A	1
51		SM-7751160-TP	SCREW	丸平小ねじ M3.5 L=10.5	1
52		SM-6040802-TP	SCREW M4X0.7 L=8	六角穴ボルト	2
53		B1634-210-D00	FINGER GUARD	指ガード	1
54		WP-0430800-SC	WASHER M4	平座金小形丸 M4	2
55		400-30621	INTERMEDIATE_PRESSER_SPRING_B	中押え補助ばね B	1
56		400-68829	PRESSURE_VARIABLE_PLATE_ASM.	中押え可変板結合	1
57		400-68832	WASHER	中押え可変板座金	1
58		SD-1002206-TP	SHOULDER SCREW D=10 H=22	段ねじ D=10 L=22	1
59		SD-0800336-TP	SHOULDER SCREW	段ねじ D=8 H=3.25	1
60		SD-0800656-TP	SHOULDER SCREW	段ねじ D=8 H=6.45	1
61		TA-0550604-R0	RUBBER PLUG	止栓	2
62	#01	400-30628	SLIDE_BLOCK_A	角駒 A	1
63	#01	400-30629	SLIDE_BLOCK_B	角駒 B	1
64	#01	400-30630	SLIDE_BLOCK_C	角駒 C	1
65		400-30616	INTERMEDIATE_PRESSER_LINK_C	中押えリンク C	1
		NOTE(注記)	#01...SELECTIVE PARTS	選択部品	

7. PRESSER MECHANISM & PRESSER VARIABLE COMPONENTS (2)

中押え・中押え可変関係 (2)

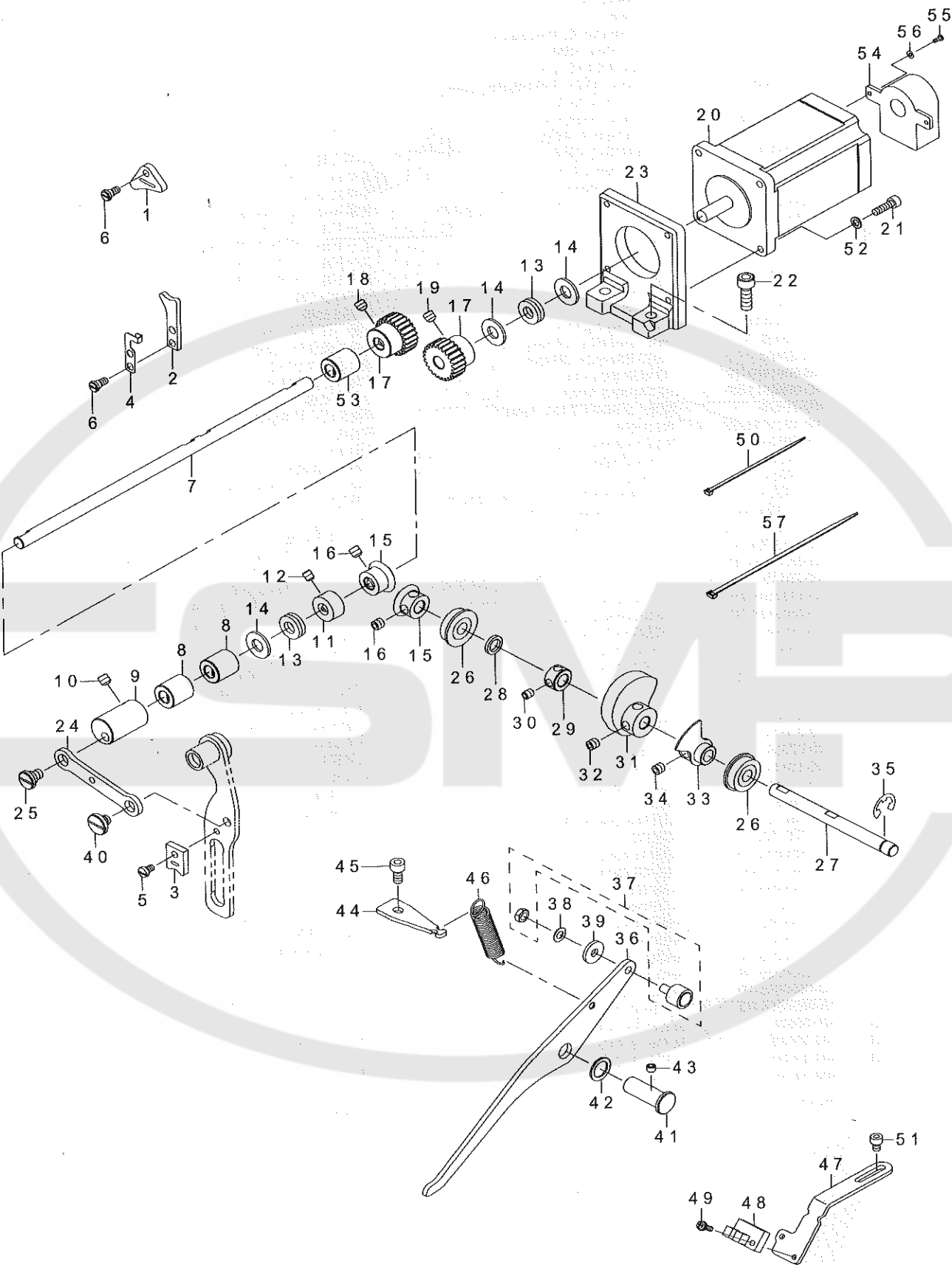

REF.NO	NOTE	PART NO	DESCRIPTION	品名	Qty
1		400-30625	FACE_FELT_A	面部フェルト A	1
2		400-30626	FACE_FELT_B	面部フェルト B	1
3		400-30627	FACE_FELT_C	面部フェルト C	1
4		400-26817	FACE_FELT_B_SUPPORT	面部フェルト B 支え	1
5		400-29420	FELT_SCREW_C	フェルト止めねじ C	1
6		400-32483	FELT_SCREW_AB	面部フェルト AB 止めねじ	3
7		400-32179	PRESSER_VARIABLE_SHAFT	中押え可変軸	1
8		400-25423	BUSHING B	メタル B	2
9		400-26819	PRESSER_VARIABLE_ARM	中押え可変腕	1
10		SM-8480652-TP	SCREW	止めねじ M6 X 0.75 L=6	2
11		CS-0800881-TP	THRUST COLLAR	スラスト受 D=8 W=8	1
12		SM-8050412-TP	SCREW M5 L=4	止めねじ M5 L=4	2
13		SB-4080001-00	BEARING	ころがり軸受	2
14		WP-0850002-SP	WASHER 8.5X18X1.6	平座金 8.5 X 18 X 1.6	3
15		400-30615	PRESSER_LIFT_GEAR	中押え上げ駆動ギア	2
16		SM-8060812-TP	SCREW M6 L=8	止めねじ M6 L=8	4
17		400-32180	PRESSER_MOTOR_GEAR_A	中押えモータギア A	2
18		SM-8060812-TP	SCREW M6 L=8	止めねじ M6 L=8	2
19		SM-8060602-TP	SCREW M6X6	止めねじ M6 L=6	2
20		400-71942	STEPPING MOTOR	ステッピングモータ	1
21		SM-6041402-TP	SCREW M4 L=14	六角穴ボルト M4	4
22		SM-6061802-TP	SCREW M6 L=18	六角穴ボルト	2
23		400-32181	PRESSER_MOTOR_BRACKET	中押えモータブラケット	1
24		400-24989	PRESSER_VARIABLE_LINK	中押え可変リンク	1
25		SD-0800337-TP	SHOULDER SCREW	段ねじ D=8 H=3.25	1
26		SB-1080005-00	RADIAL BEARING	ラジアル軸受	2
27		400-25426	PRESSER_LIFT_SHAFT	中押え上げ軸	1
28		WZ-0850302-K0	WAVED WASHER 8.5X12.5X0.3	波形座金 8.5 X 12.5 X 0.3	1
29		CS-0800881-TP	THRUST COLLAR	スラスト受 D=8 W=8	1
30		SM-8050412-TP	SCREW M5 L=4	止めねじ M5 L=4	2
31		400-25016	LIFTING_CAM	中押え上げカム	1
32		SM-8060812-TP	SCREW M6 L=8	止めねじ M6 L=8	2
33		400-25418	SENSOR_SLIT_ASM	センサースリット組	1
34		SM-8060812-TP	SCREW M6 L=8	止めねじ M6 L=8	2
35		RE-0700000-K0	E-RING 7	E 形止め輪 7	1
36		400-25030	LIFTING_LINK	中押え上げリンク	1
37		400-27870	CAM FOLLOWER	中押え上げカムフォロア	1
38		WP-0520656-SA	WASHER 5.2X9.5X0.6	平座金 5.2 X 9.5 X 0.6	1
39		WP-0522016-SH	WASHER	平座金 5.2 X 15 X 2	1
40		SD-0800387-TP	SHOULDER SCREW D=8 H=3.75	段ねじ D=8 H=3.75	1
41		B1641-562-000	FEED REGULATING ARM SHAFT	送り調節腕軸	1
42		262-26001	WASHER	糸切りリンク座金	1
43		SM-8050412-TP	SCREW M5 L=4	止めねじ M5 L=4	1
44		400-25420	LIFTER_LINK_SPRING_HOOK	中押え上げばね掛け	1
45		SM-6050802-TP	SCREW M5X0.8 L=8	六角穴ボルト M5 X 0.7 L=8	1
46		400-03970	TENSION RELEASE RETURN	ばね	1
47		400-25419	SENSOR_INSTALLING_BASE	センサー取付板	1
48		HD-0005700-0A	PHOTO SENSOR	フォトセンサ	1
49		SL-4031091-SC	SCREW M3 X 10	なべ小ねじセムス	1
50		EA-9500B01-00	CABLE BAND	束線バンド	2
51		SM-6040602-TP	SCREW M4 L=6	六角穴ボルト M4 X 0.7 L=6	2
52		WP-0450846-SP	WASHER	平座金	4
53		400-43321	BUSHING_C	中押え可変軸メタル	1
54		HD-0027800-00	SENSOR	センサー	1
55		SM-4020501-SC	SCREW M2 L=5	なべ小ねじ M2 L=5	2
56		WP-0220301-SC	WASHER M2	平座金みがき丸 M2	2
57		EA-9500B02-00	CABLE BAND 150	結束バンド 150	2

8. SHUTTLE DRIVER SHAFT COMPONENTS (1)

下軸関係 (1)

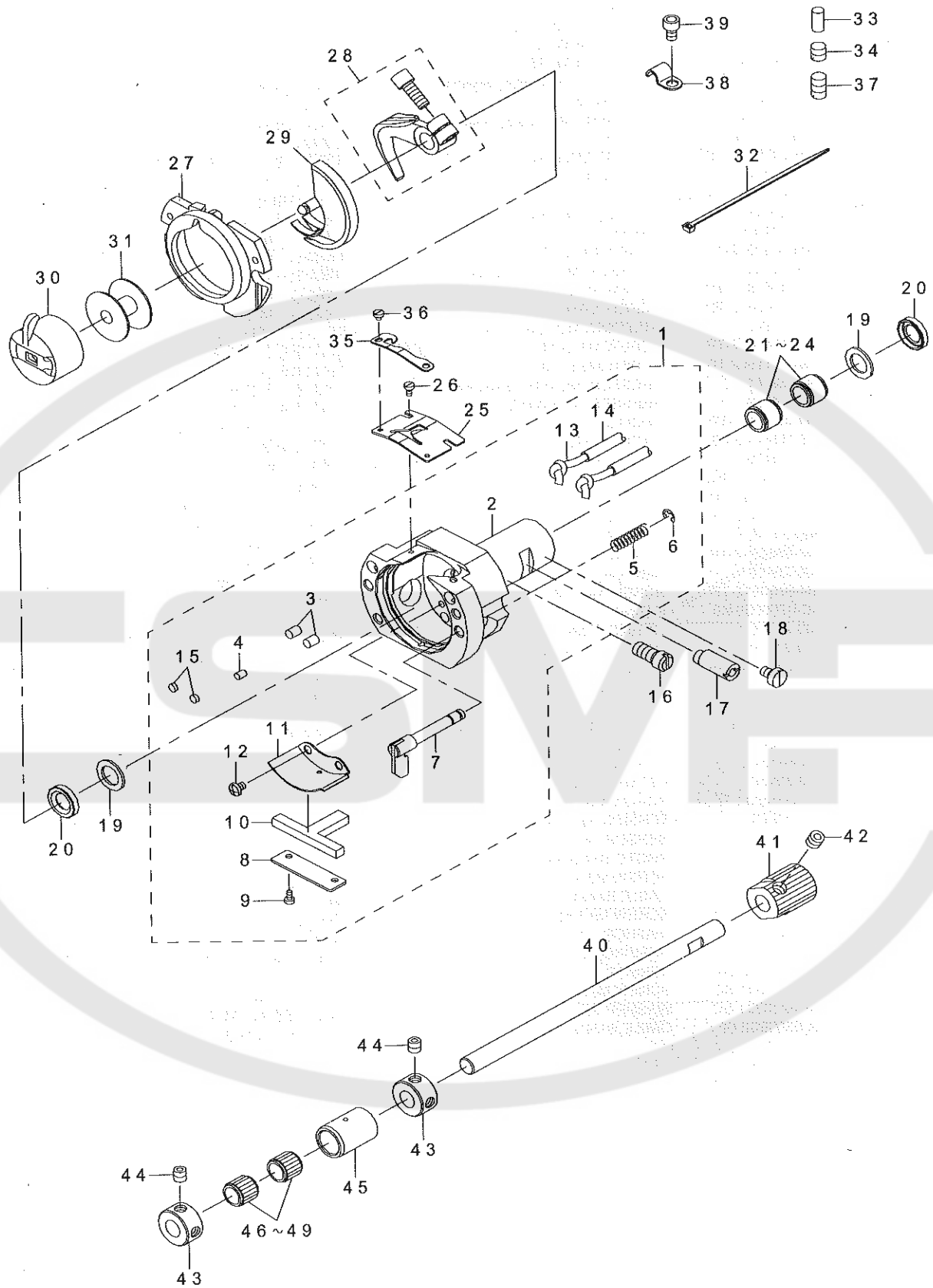

REF.NO	NOTE	PART NO	DESCRIPTION	品名	Qty
1		400-72140	SHUTTLE_ASM	大釜組	1
2		400-06574	SHUTTLE	大釜	(1)
3		B1820-210-D00	SHUTTLE OIL FELT,A	大釜給油穴フェルト A	(2)
4		B1821-210-D00	SHUTTLE OIL FELT,B	大釜給油穴フェルト B	(1)
5		B1822-215-P00	INNER HOOK PRESSER SPRING	中金押えばね	(2)
6		RE-0300000-K0	E-RING 3	E 形止め輪 3	(2)
7		265-01858	INNER-HOOK-PRESSER COMPL.	中金押えフック結合	(2)
8		141-04004	ONCE THROUGH OIL FELT PRESSER	大釜還流フェルト押え	(1)
9		SM-6020460-TP	SCREW	平ねじ M 2 L = 3. 5	(2)
10		141-03907	SHUTTLE ONCE THROUGH OIL FELT	大釜還流フェルト	(1)
11		400-06577	SHUTTLE_LUBRICATING_PLATE	大釜給油板	(1)
12		SM-4030455-SP	SCREW	なべ小ねじ M 3 L = 4	(2)
13		CQ-2000000-00	OIL WICK	油芯	(8.9)
14		236-30007	TUBE	チューブ	(3.9)
15		135-29607	SHUTTLE PACKING	大釜パッキン	(2)
16		400-10470	SHUTTLE_ASM_SCREW	大釜組止めねじ	1
17		400-10471	SHUTTLE_RACE_ADJUSTING_SHAFT	大釜調節軸	1
18		SM-6060800-SP	SCREW M6 L=8	平ねじ M 6 L = 8	1
19		400-10472	SHUTTLE_BEARING_RING	大釜ベアリング止め輪	2
20		400-06576	SHUTTLE_OIL_SEAL	オイルシール	2
21	#01	SB-3080010-0A	BEARING	ころがり軸受	2
22	#01	SB-3080010-0B	BEARING	ころがり軸受	2
23	#01	SB-3080010-0C	BEARING	ころがり軸受	2
24	#01	SB-3080010-0D	BEARING	ころがり軸受	2
25		400-36117	SHUTTLE UPPER SPRING	大釜上ばね	1
26		SM-6020460-TP	SCREW	平ねじ M 2 L = 3. 5	2
27		141-03352	INNER HOOK PRESSER ASM., B	中金押え B 結合	1
28	☆	400-14963	SHUTTLE DRIVER ASM.	ドライバー組	1
29	☆	#02 400-61991	SHUTTLE(H)	中金 (太針用)	1
30	☆	B1828-210-DAA	BOBBIN CASE ASM.	ボビンケース組	1
31	☆	B1806-210-D00	BOBBIN	ボビン	1
32		EA-9500B01-00	CABLE BAND	束線バンド	2
33		400-06578	OIL_WICK_PRESSER	釜給油油絞り	1
34		SM-8060610-TP	SCREW	止めねじ M 6 L = 6	1
35		400-36118	LOWER THREAD HOLDER	下糸保持板	1
36		SM-6020250-TP	SCREW	平ねじ	2
37		SM-8061050-TP	SCREW	止めねじ M 6 L = 10	1
38		B3538-112-000	OIL RETURN TUBE HOLDER	還流パイプ押え	1
39		SM-6040602-TP	SCREW M4 L=6	六角穴ボルト M 4 X 0. 7 L = 6	1
40		400-72102	DRIVER SHAFT	下軸ギヤ軸	1
41		400-72101	LOWER SHAFT GEAR	下軸ギヤ	1
42		SM-8060552-TP	SCREW M6 L=5	止めねじ	2
43		CS-0800971-TP	THRUST COLLAR D=8 W=9	スラストカラー D = 8 W = 9	2
44		SM-8050512-TP	SCREW	止めねじ M 5 L = 5	4
45		B1847-221-D00	LOWER SHAFT MIDDLE METAL	下軸中メタル	1
46	#01	B1411-804-A00	BEARING (A)	針駆動レバーベアリング A	1
47	#01	B1411-804-B00	NEEDLE DRIVING LEVER BEARING B	針駆動レバーベアリング B	1
48	#01	B1411-804-C00	NEEDLE DRIVING LEVER BEARING C	針駆動レバーベアリング C	1
49	#01	B1411-804-D00	BEARING (D)	針駆動レバーベアリング D	1
		NOTE(注記)	#01.....SELECTIVE PARTS	選択部品	
			#02.....TYPE H	H仕様	

9. SHUTTLE DRIVER SHAFT COMPONENTS (2)
 下軸関係 (2)

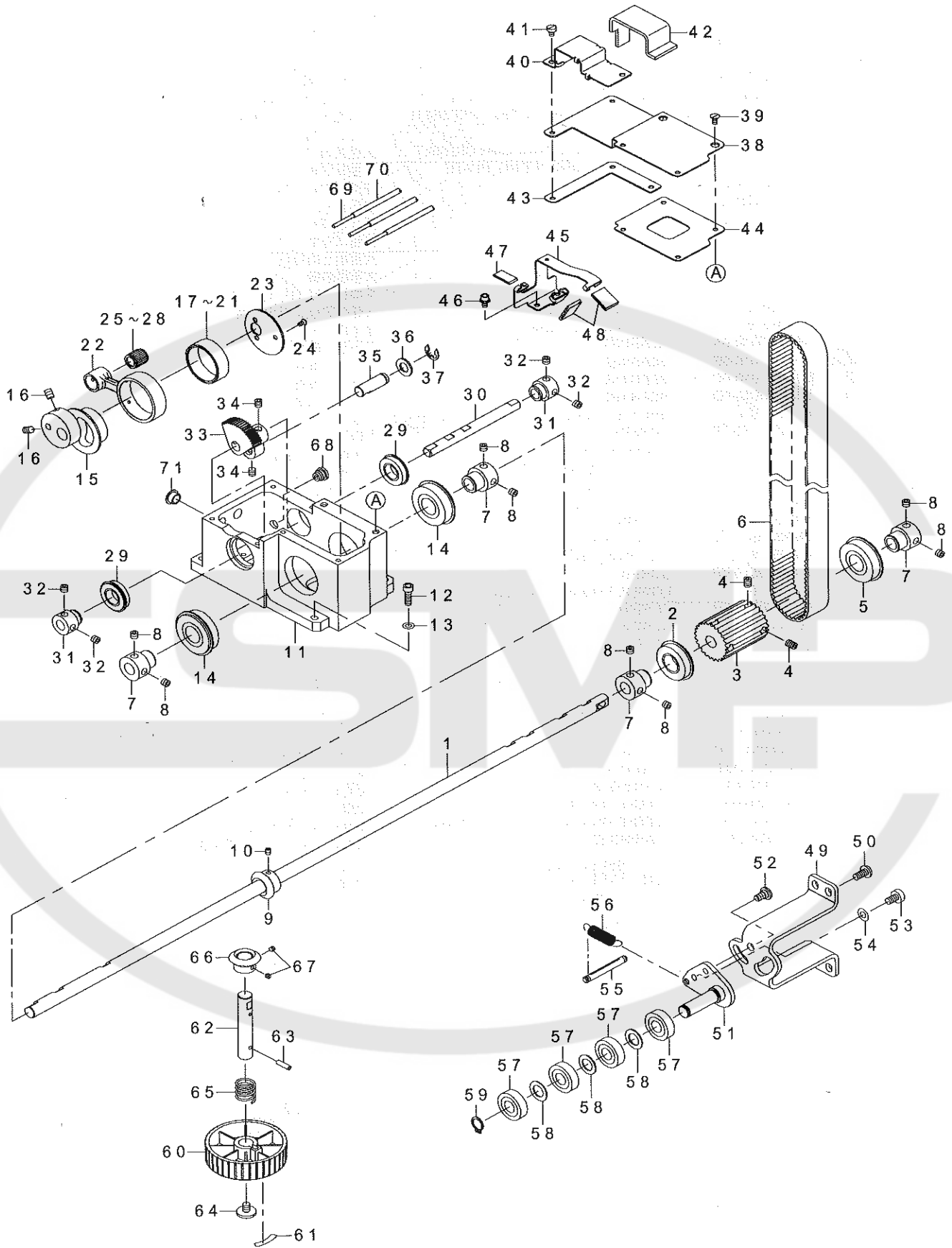

REF.NO	NOTE	PART NO	DESCRIPTION	品名	Qty
1		400-72089	LOWER SHAFT	下軸	1
2		SB-1170004-00	BEARING	ころがり軸受	1
3		400-72207	LOWER SHAFT SPROCKET	下軸スプロケット	1
4		SM-8060812-TP	SCREW M6 L=8	止めねじ M6 L=8	4
5		SB-1170010-00	BEARING	ころがり軸受	1
6		400-72088	BELT	上軸タイミングベルト	1
7		236-18606	BEARING SUPPORT	上下軸前ベアリング受	4
8		SS-8660512-TP	SCREW 1/4-40 L=5	止ねじ 1/4-40 L=5	8
9		400-72173	GEAR_A	手元プーリー歯車A	1
10		SM-8040502-TP	SCREW M4X0.7 L=5	止めねじ M4 X 0.7 L=5	2
11		400-72090	GEAR BOX	下軸ギアボックス	1
12		SM-6051602-TP	SCREW M5X0.8 L=16	六角穴ボルト M5 X 0.8 L=16	4
13		WP-0531000-SD	WASHER M5	平座金小形丸 M5	4
14		SB-1170011-00	BEARING	ころがり軸受	2
15		400-72091	ECCENTRICK CAM	下軸偏芯カム	1
16		SM-8060812-TP	SCREW M6 L=8	止めねじ M6 L=8	2
17		SB-3350002-0A	BEARING	ころがり軸受	1
18		SB-3350002-0B	BEARING	ころがり軸受	1
19		SB-3350002-0C	BEARING	ころがり軸受	1
20		SB-3350002-0D	BEARING	ころがり軸受	1
21		SB-3350002-0E	BEARING	ころがり軸受	1
22		400-72092	CRANK LOD	下軸クランクロッド	1
23		400-72106	CRANK LOD SUPPORT PLATE	クランクロッド補助板	1
24		SM-1030601-SP	SCREW M3 L=6	皿ねじ M3 L=6	3
25		SB-3100011-0A	BEARING	ころがり軸受	1
26		SB-3100011-0B	BEARING	ころがり軸受	1
27		SB-3100011-0C	BEARING	ころがり軸受	1
28		SB-3100011-0D	BEARING	ころがり軸受	1
29		SB-1150014-00	BEARING	ころがり軸受	2
30		400-72093	OSCILLATING SHAFT	大振り軸	1
31		400-72227	BEARING_BUSH	ベアリングブッシュ	2
32		SM-8060552-TP	SCREW M6 L=5	止めねじ	4
33		400-72094	OSCILLATOR	大振り子	1
34		SM-8480652-TP	SCREW	止めねじ M6 X 0.75 L=6	5
35		400-72095	OSCILLATOR PIN	大振り子ピン	1
36		400-26818	WASHER	大振り子ピン座金	1
37		RE-0800000-K0	E-SHAPED SNAP RING (8MM)	E形止め輪 8	1
38		400-72096	GEAR BOX COVER	ギアボックスカバー	1
39		SM-1040870-TP	SCREW	皿小ねじ M4 L=8	2
40		400-72100	LUBRICATING PLATE	給油板	1
41		SM-6040650-TP	SCREW	平ねじ M4 L=6	5
42		400-72099	FELT	給油フェルト	1
43		400-72097	GASKET A	パッキンA	1
44		400-72098	GASKET B	パッキンB	1
45		400-72159	LUBRICATION PLATE	給油板	1
46		SL-6040892-TN	BOLT	座金付き六角穴ボルト	2
47		B3518-280-000	BALANCE LUBRICATING	天秤給油パイリオン	1
48		B3509-280-000	NEEDLE ROD CRANK LUBRICATING	針棒クランク給油パイリオン	2
49		400-72208	IDLER INSTALLING PLATE	アイドラー取付板	1
50		SM-4061255-SP	SCREW M6 L=12	なべねじ M6 L=12	4
51		400-72103	IDLER BASE ASM	アイドラー基台結合	1
52		SD-0800346-TP	SHOULDER SCREW	段ねじ D=8 H=3.4	1
53		SM-6061010-TP	SCREW M6 L=10	平小ねじ M6 L=10	1
54		WP-0641601-SD	WASHER M6	平座金みがき丸 M6	1
55		135-18501	SPRING SUSPENSION	布押えばね掛け	1
56		144-32504	IDLER SPRING	アイドラーばね	1
57		SB-1120002-00	BEARING	ベアリング D=12 X 28	4
58		WP-1221016-SP	WASHER	平座金	3
59		RC-1200001-KP	C-SHAPED SNAP RING	C形止め輪	1
60		B1212-210-D00	PULLEY	手元プーリー	1
61		B1144-210-000	REVOLVING DIRECTION LABEL	回転方向ラベル	1
62		B1213-210-D00	PULLEY SHAFT	手元プーリー軸	1
63		PS-0400142-KH	SPRING PIN 4X14	スプリングピン 4 X 14	1
64		A1230-500-000-A	HANDWHEEL SETSCREW	はずみ車止めねじ	1
65		GAF-01007000	SPRING	送り固定ばね	1
66		400-06515	GEAR_A	ギアA	1
67		SM-8040502-TP	SCREW M4X0.7 L=5	止めねじ M4 X 0.7 L=5	2
68		400-06840	RUBBER BUSH	止栓	3
69		CQ-2000000-00	OIL WICK	油芯	2.6
70		236-30007	TUBE	チューブ	6.3
71		TA-1050504-R0	RUBBER PLUG	止栓	2

10. WIPER MECHANISM COMPONENTS

ワイパー関係

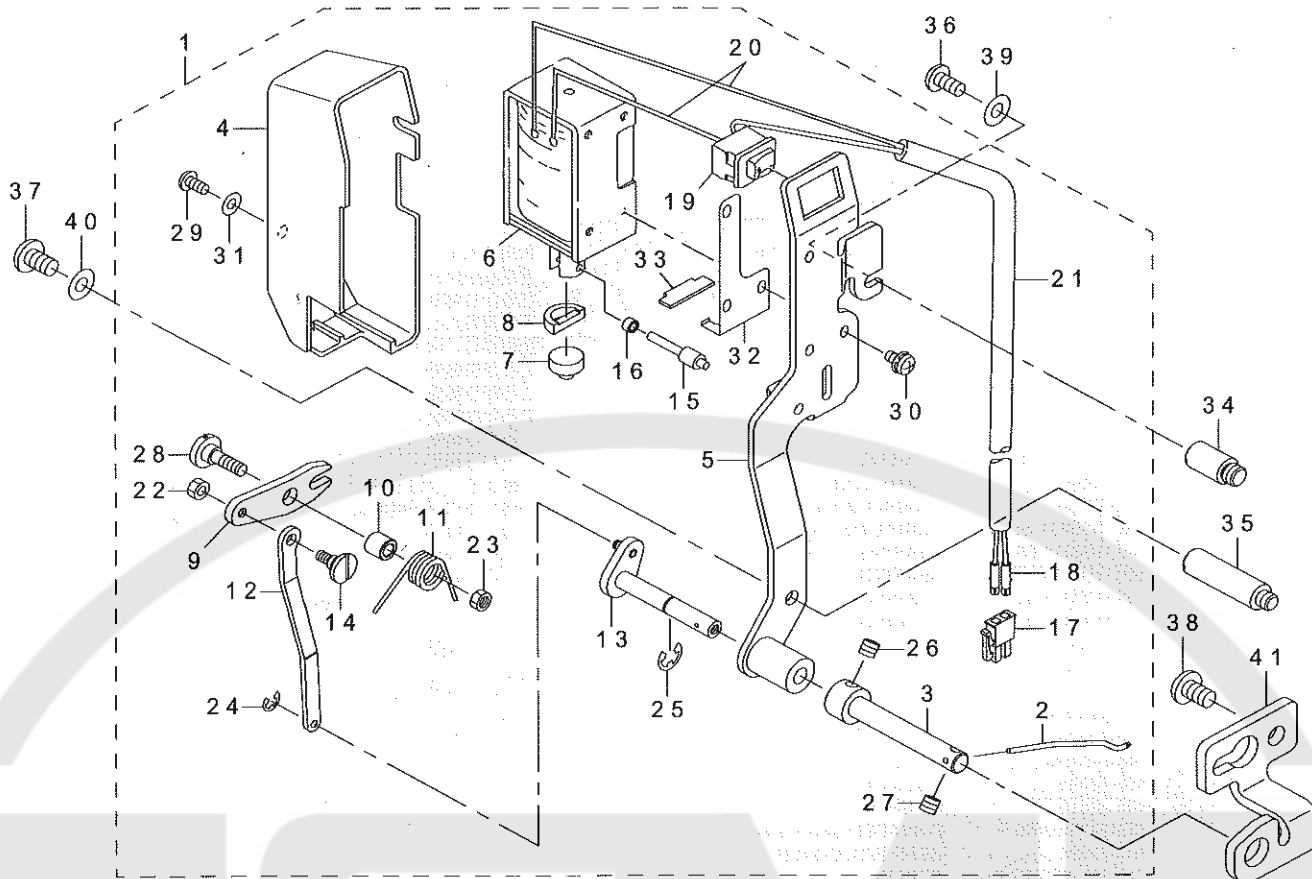

REF.NO	NOTE	PART NO	DESCRIPTION	品名	Qty
1		400-72151	WIPER ASM	ワイパー組	1
2	☆	B2107-210-D00	WIPER	ワイパー	(1)
3		400-25416	WIPER_SHAFT_CAP	ワイパーキャップ	(1)
4		229-55504	WIPER COVER	ワイパーカバー	(1)
5		400-30780	WIPER_BASE_ASM.	ワイパー台組	(1)
6		400-30956	WIPER SOLENOID	ワイパーソレノイド	(1)
7		229-55900	WIPER RUBBER A	ワイパーゴム A	(1)
8		229-56007	WIPER RUBBER B	ワイパーゴム B	(1)
9		229-56106	WIPER LINK A	ワイパーリンク A	(1)
10		229-56205	WIPER HINGE SCREW COLLAR	ワイパー段ねじカラー	(1)
11		B2130-210-D00	WIPER SPRING	ワイパーばね	(1)
12		400-30779	WIPER_LINK_B	ワイパーリンク B	(1)
13		111-11051	WIPER DRIVING SHAFT ASM.	ワイパー軸組	(1)
14		229-56908	WIPER LINK B HINGE SCREW	ワイパーリンク B 段ねじ	(1)
15		229-57104	WIPER SOLENOID SHAFT	ワイパーソレノイド軸	(1)
16		229-57203	WIPER LINK COLLAR	ワイパーリンクカラー	(1)
17		HK-0346100-20	2-POLE NYLON PLUG	ハウジング 2 P	(1)
18		HK-0346400-0B	PIN CONTACT	ピンコンタクト	(2)
19		HA-0060000-00	SWITCH	スイッチ	(1)
20		HW-2003900-00	ELECTRIC WIRE	ビニール電線 17-0.16 白	(0.04)
21		HW-5000700-00	2-CORE CABTYRE CORD	2芯キャブタイヤコード	(2.5)
22		NS-6090310-SP	NUT 9/64-40	六角ナット 9/64-40	(1)
23		NS-6110310-SP	NUT 11/64-40	六角ナット 11/64-40	(1)
24		RE-0250000-K0	E-RING 2.5	E 形止め輪 2.5	(1)
25		RE-0500000-K0	E-RING	E 形止め輪 5	(1)
26		SM-8040412-TP	SET SCREW M4 L=4	止めねじ	(1)
27		SM-8040412-TP	SET SCREW M4 L=4	止めねじ	(1)
28		SD-0650321-TP	HINGE SCREW D=6.5 H=3.2	段ねじ D=6.5 H=3.2	(1)
29		SM-4030601-SN	SCREW M3 X 6	なべ小ねじ M3 X 0.5 L=6	(1)
30		SL-4030641-SE	SCREW	座金付きねじ	(3)
31		WP-0320501-SC	WASHER M3	平座金 3.2 X 7 X 0.5	(1)
32		400-37500	RUBBER HOLDER	ゴム支え板	(1)
33		400-37501	STOPPER RUBBER	ストッパーゴム	(1)
34		400-25440	WIPER_STUD_TOP	ワイパースタッド上	1
35		400-25441	WIPER_STUD_BOTTOM	ワイパースタッド下	1
36		SM-4040855-SP	SCREW	なべねじ	1
37		SM-4050855-SP	SCREW	なべねじ	1
38		SM-4041055-SP	SCREW	なべねじ M4 L=10	2
39		WP-0450801-SP	WASHER	平座金	1
40		WP-0531001-SC	WASHER	平座金みがき丸 M5	1
41		B2110-210-D00	WIPER SHAFT SUPPORT BRACKET	ワイパー軸受	1

11. TENSION RELEASE & THREAD TENSION COMPONENTS

糸ゆるめ・糸調子関係

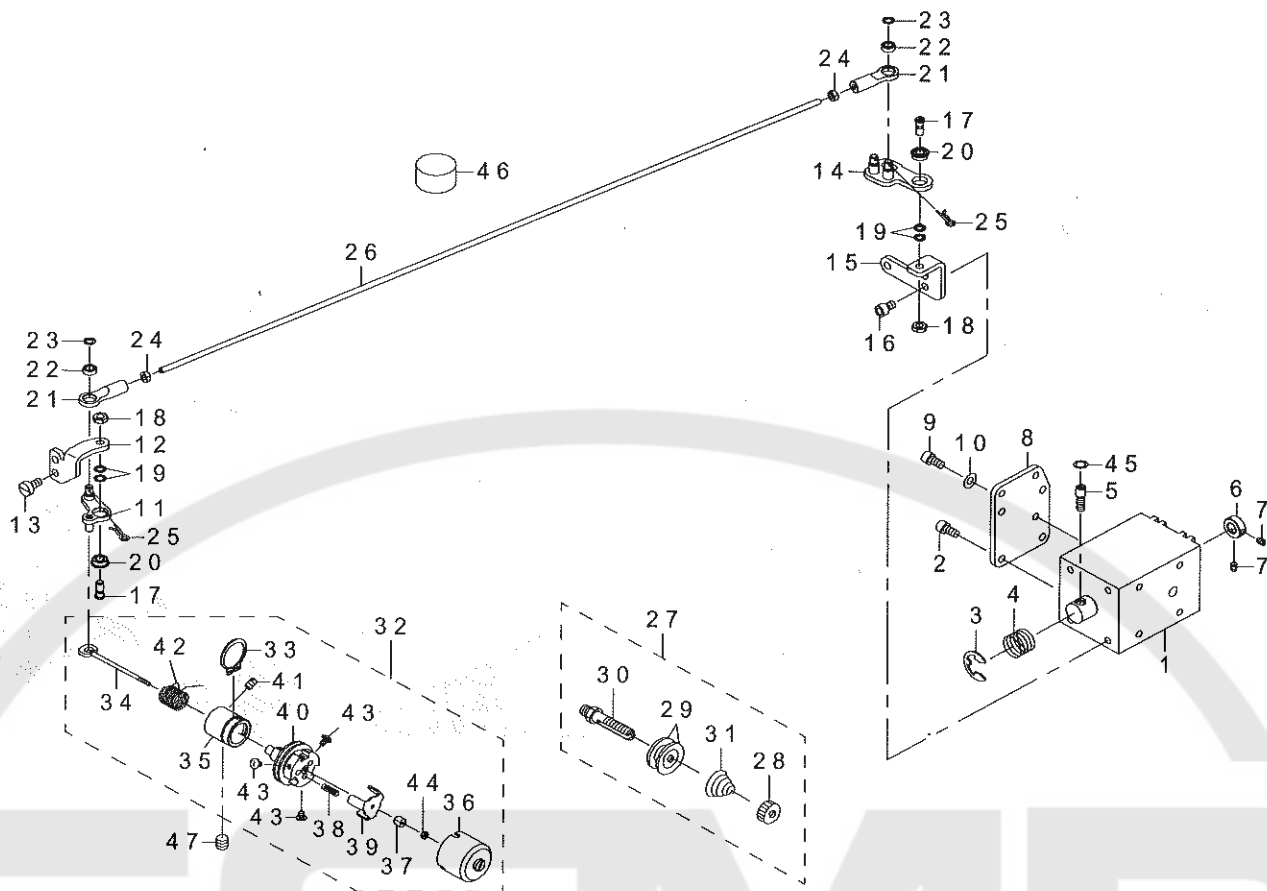

REF.NO	NOTE	PART NO	DESCRIPTION	品名	Qty
1		400-73660	AT SOLENOID	A T ソレノイド	1
2		SM-6040802-TP	SCREW M4X0.7 L=8	六角穴ボルト	4
3		RE-0900000-K0	E-RING 9	E 形止め輪 9	1
4		400-06625	SPRING	A T ソレノイド戻しばね	1
5		400-06617	AT_SOL_PIN	A T ソレノイドピン	1
6		400-10477	AT_SOL_COLLAR	A T ソレノイドストッパーカラー	1
7		SM-8030412-TP	SCREW	止めねじ M3 L=4	2
8		400-10479	AT_PLATE	A T ソレノイド取付板	1
9		SM-6040802-TP	SCREW M4X0.7 L=8	六角穴ボルト	2
10		WP-0430801-SC	WASHER 4.3X9X0.8	平座金 4.3 X 9 X 0.8	2
11		400-32343	AT_DRIVE_LINK_F_ASM	A T 駆動リンク前組	1
12		400-23993	AT_PIVOT_BASE(F)	A T 駆動リンク前支点台	1
13		SM-6040860-TP	SCREW M4 L=8	平ねじ M4 L=8	2
14		400-32345	AT_DRIVE_LINK_R_ASM	A T 駆動リンク後ろ組	1
15		400-23999	AT_PIVOT_BASE(R)	A T 駆動リンク後ろ支点台	1
16		SM-6040802-TP	SCREW M4X0.7 L=8	六角穴ボルト	2
17		400-10487	AT_PIVOT_SCREW	A T 駆動リンク支点ねじ	2
18		NM-6040003-SC	NUT M4	六角ナット M4	2
19		400-10489	AT_PIVOT_SCREW_WASHER	A T 駆動リンク支点ねじ座金	4
20		400-10490	AT_PIVOT_BEARING	A T 駆動リンク支点ベアリング	2
21		400-10497	AT_JOINT	A T 駆動継ぎ手	2
22		400-10498	AT_JOINT_BEARING	A T 駆動継ぎ手ベアリング	2
23		400-10489	AT_PIVOT_SCREW_WASHER	A T 駆動リンク支点ねじ座金	2
24		400-10499	AT_JOINT_NUT	A T 駆動継ぎ手ナット	2
25		400-06622	AT_SNAP_PIN	まつばピン	2
26		400-72111	AT CONNECTION BAR	A T 連結棒	1
27		400-10503	THREAD_TENSION_1_ASM	第一糸調子組	1
28		229-28808	NUT	糸調子ナット	(1)
29		229-21506	THREAD TENSION DISK	糸調子皿	(2)
30		400-10504	THREAD_TENSION_SHAFT	糸調子軸	(1)
31		262-18602	FIRST THREAD TENSION SPRING	第一糸調子ばね	(1)
32	#01	400-29411	THREAD_TENSION_2_ASM_H	第二糸調子組	1
33		400-10523	POST_BASE_C_RING	糸調子ストッパー C リング	(1)
34		400-10509	TENSION RELEASE PIN	糸緩めピン	(1)
35		400-10510	THREAD_TENSION_POST_BASE	糸調子台	(1)
36		400-10511	DISK_STOPPER HOLDER_CAP	糸調子キャップ	(1)
37		400-10512	THREAD_TENSION_SHAFT_COLLAR	糸緩めピン調節カラー	(1)
38		400-10513	DISK_STOPPER_SPRING	糸調子皿戻しばね	(3)
39		400-10514	DISK_STOPPER	糸調子皿押え板	(1)
40		400-10515	ASSY_THREAD_TENSION_POST	糸調子棒組	(1)
41		400-10478	AT_SOL_COLLAR_SCREW	A T ソレノイドストッパーカラー止めねじ	(1)
42	☆ #01	400-29412	THREAD_TAKE-UP_SPRING_H	糸取りばね	(1)
43		400-10521	HOLD_CAP_SCREW	糸調子キャップ止めねじ	(3)
44		400-10522	SHAFT_NUT	糸緩めピン調節カラー止めナット	(1)
45		WP-0510516-SD	WASHER 5.1X7.5X0.5	平座金 5.1 X 7.5 X 0.5	2
46		B1228-232-000	OIL FELT	油溜めフェルト	1
47		SM-8061612-TP	SCREW M6X16	止めねじ M6 L=16	1
		NOTE(注記)	#01...TYPE H	H 仕様	

12. THREAD TRIMMER MECHANISM COMPONENTS

糸切り関係

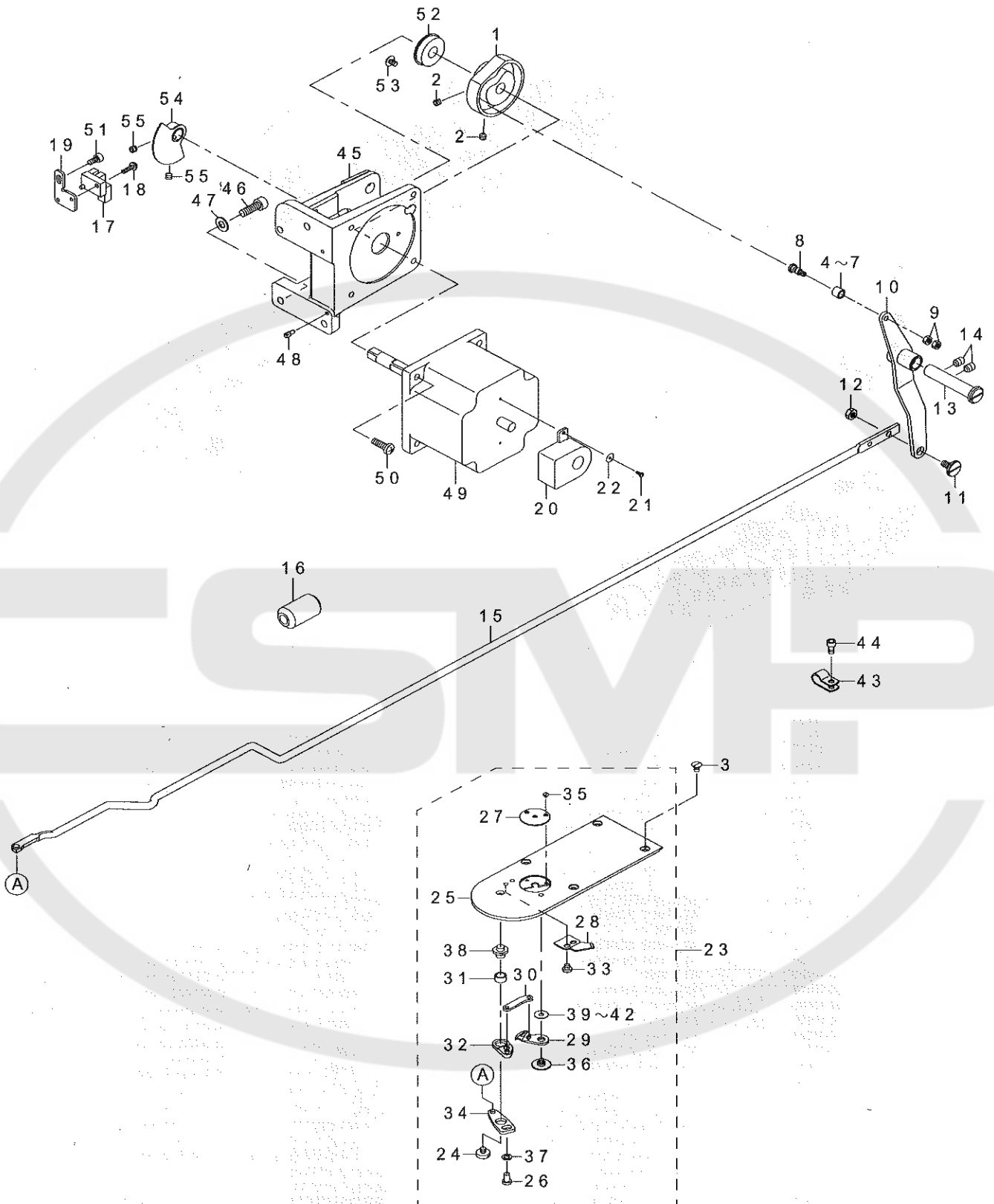

REF.NO	NOTE	PART NO	DESCRIPTION	品名	Qty
1		400-30936	THREAD_TRIMMER_CAM	糸切りカム	1
2		SM-8050592-TP	SCREW	止めね M5 L=5	2
3	*	SM-1040650-TP	SCREW	皿ねじ M4 L=6	4
4	#01	235-17501	NEEDLE CAM ROLLER A	針振りカムコロ A	1
5	#01	235-17600	NEEDLE CAM ROLLER B	針振りカムコロ B	1
6	#01	235-17709	NEEDLE CAM ROLLER C	針振りカムコロ C	1
7	#01	235-17808	NEEDLE CAM ROLLER D	針振りカムコロ D	1
8		400-40256	ROLLER_SHAFT	カムコロ軸	1
9		NM-6040001-SP	NUT M4X0.7	六角ナット M4 X 0.7 1種	2
10		400-72228	THREAD_TRIMMER_LINK_ASM	糸切りリンク組	1
11		SD-0800327-TP	SHOULDER SCREW	段ねじ D=8 H=3.2	1
12		NM-6050001-SP	NUT M5	六角ナット M5 X 0.8 1種	1
13		400-23624	THREAD_TRIMMER_SHAFT	糸切りリンク軸	1
14		SM-8060812-TP	SCREW M6 L=8	止めねじ M6 L=8	2
15		400-72107	THREAD TRIMMER CONNECTING BAR	糸切り連結棒	1
16	#03	HN-0028400-00	CORES	フェライトコア	1
17		HD-0005700-0A	PHOTO SENSOR	フォトセンサー	1
18		SL-4031091-SC	SCREW M3 X 10	なべ小ねじセムス	1
19		400-10443	SENSOR_INSTALLING_BASE	押え上げセンサー取付板	1
20		HD-0027800-00	SENSOR	センサー	1
21		SM-4020501-SC	SCREW M2 L=5	なべ小ねじ M2 L=5	2
22		WP-0220301-SC	WASHER M2	平座金みがき丸 M2	2
23	#02	400-30933	NEEDLE_PLATE_H_ASM.	H仕様針板組	1
24		SS-6110430-TP	SCREW 11/64-40 L=4.0	平ねじ 11/64-40 L=4	(1)
25		400-30934	NEEDLE_PLATE	針板	(1)
26		SS-7110740-TP	SCREW 11/64-40 L=7	丸平ねじ 11/64-40 L=7	(1)
27	☆	#02 B2426-210-00B	NEEDLE HOLE GUIDE D=2.0	針穴ガイド	(1)
28	☆	B2424-210-000	COUNTER KNIFE	固定メス	(1)
29	☆	B2421-210-AA0	MOVING KNIFE COMPL.	動メス結合	(1)
30		B2418-280-000	MOVING KNIFE LINK	動メスリンク	(1)
31		B2416-280-000	THREAD CUTTING LEVER RING	糸切りレバーリング	(1)
32		B2415-280-0A0	THREAD CUTTER LEVER ASM., SMALL	糸切りレバー (小) 組	(1)
33		SS-7090410-SP	SCREW 9/64-40 L=3.5	丸平ねじ 9/64-40 L=3.5	(2)
34		B2414-280-0A0	THREAD CUTTER LEVER ASM., LARGE	糸切りレバー (大) 組	(1)
35	☆	SS-1060210-TP	SCREW 3/32-56 L=2.2	皿ねじ 3/32-56 L=2.2	(2)
36		B2417-210-000	MOVING KNIFE HINGE SCREW	動メス段ねじ	(1)
37		WP-0450846-SP	WASHER	平座金	(1)
38		B2417-280-000	THREAD CUTTER LEVER SHAFT	糸切りレバー軸	(1)
39	#01	B2423-280-00D	MOVING KNIFE WASHER D	動メス座金 D	(1)
40	#01	B2423-280-00B	MOVING KNIFE WASHER B	動メス座金 B	(1)
41	#01	B2423-280-00A	MOVING KNIFE WASHER A	動メス座金 A	(1)
42	#01	B2423-280-00C	MOVING KNIFE WASHER C	動メス座金 C	(1)
43		HX-0015000-0C	CABLE CLIP	束線パーツ	1
44		SM-6040802-TP	SCREW M4X0.7 L=8	六角穴ボルト	1
45		400-72211	MOTOR_BASE	モータ取付台	1
46		SM-6061802-TP	SCREW M6 L=18	六角穴ボルト	3
47		WP-0651001-SC	WASHER	平座金	3
48		B1816-215-P00	GUIDE PIN	中釜押えガイドピン	2
49		400-71944	STEPPING MOTOR	ステッピングモータ	1
50		SM-4051655-SP	SCREW M5 L=16	なべねじ M5 L=16	4
51		SM-6040802-TP	SCREW M4X0.7 L=8	六角穴ボルト	1
52		SB-1100024-00	BEARING	ころがり軸受	1
53		SM-6040650-TP	SCREW	平ねじ M4 L=6	1
54		400-06666	SENSOR_SLIT_ASM	センサースリット組	1
55		SM-8050592-TP	SCREW	止めねじ M5 L=5	2

NOTE(注記) #01.....SELECTIVE PARTS
#02.....TYPE H
#03.....FOR JE

選択部品
H仕様
JE用

13. THREAD CLAMP COMPONENTS

糸掴み関係

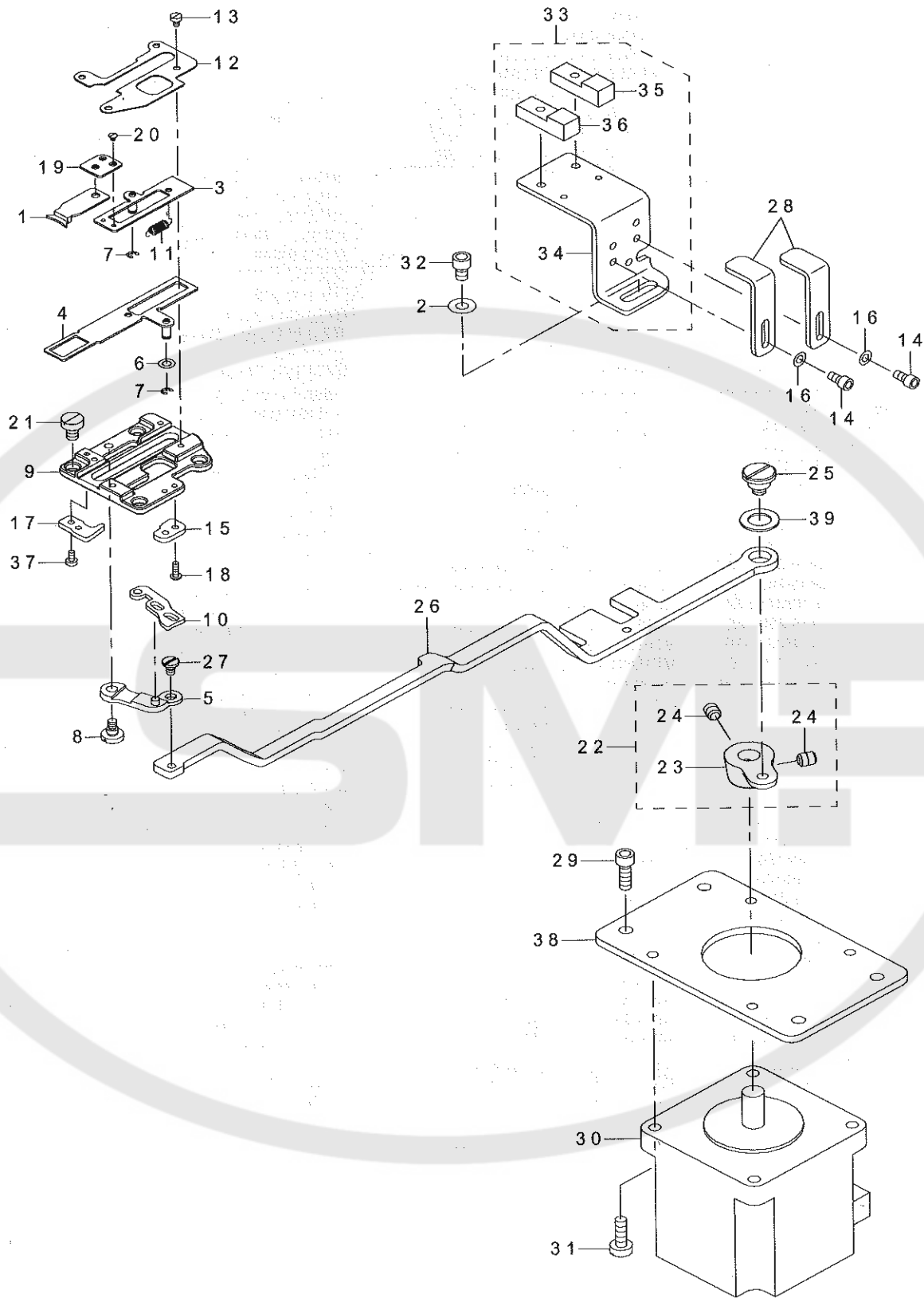

REF.NO	NOTE	PART NO	DESCRIPTION	品名	Qty
1		400-06761	TC_CLAMP	糸掴み	1
2		WP-0450801-SP	WASHER	平座金	1
3		400-06762	TC_CLAMP_PLATE_ASM.	糸掴み板組	1
4		400-06765	TC_SUPPERT_PLATE_ASM.	糸掴み板支え板組	1
5		400-15800	TC_LINK_ASM.	糸掴み板リンク組	1
6		WP-0320500-SC	WASHER M3	平座金小形丸 M3	1
7		RE-0200000-K0	E-RING	E 形止め輪 2	2
8		SD-0400266-TP	SHOULDER SCREW	段ねじ D=4 H=2.6	1
9		400-10589	TC BASE	糸掴み板土台	1
10		400-06772	TC_CAM_PLATE	糸掴み板カム板	1
11		400-06780	TC_SPRING	糸掴み板ばね	1
12		400-06781	TC_BASE_COVER	糸掴み板土台カバー	1
13		SM-6020350-SP	SCREW M2 L=2.5	平ねじ M2 L=2.5	4
14		SM-6030602-TP	SCREW M3X0.5 L=6	六角穴ボルト M3 X 0.5 L=6	4
15	#01	400-30943	TC_NOTCH_R_H	糸掴み板ノッチ R_H	1
16		WP-0320500-SD	M3 WASHER	平座金 M3	4
17	#01	400-30942	TC_NOTCH_F_H	糸掴み板ノッチ F_H	1
18		SM-4020600-SP	SCREW M2 L=6	なべ小ねじ M2 L=6	2
19		400-06768	TC_JOINT_ASM.	糸掴み板ジョイント組	1
20		SM-2360110-TP	SCREW	丸皿ねじ M1.6 X 0.2 L=1.35	2
21		SM-6040650-TP	SCREW	平ねじ M4 L=6	4
22		400-10527	TC_DRIVING_ARM_ASM.	糸掴み板駆動腕組	1
23		400-10528	TC_DRIVING_ARM	糸掴み板駆動腕	(1)
24		400-11152	TC_ARM_SCREW	糸掴み板駆動腕ねじ	(2)
25		SD-0800407-TP	SHOULDER SCREW	段ねじ D=8 H=4	1
26		400-72108	TC CONNECTING LINK	糸掴み連結リンク	1
27		SD-0350156-TP	SHOULDER SCREW	段ねじ D=3.5 H=1.5	1
28		400-72225	CONNECTING_LINK_SUPPORT	糸掴み連結リンク支え板	2
29		SM-6041202-TP	SCREW M4X0.7 L=12	六角穴ボルト	3
30		400-75079	STEPPING MOTOR	ステッピングモータ	1
31		SM-6041202-TP	SCREW M4X0.7 L=12	六角穴ボルト	4
32		SM-6040602-TP	SCREW M4 L=6	六角穴ボルト M4 X 0.7 L=6	1
33		400-73674	TH SENSOR ASM	糸掴み板センサー組	1
34		400-72109	TC SENSOR INSTALLING PLATE	糸掴みセンサー取付板	(1)
35		HD-0020400-0A	SENSOR	センサー	(1)
36		HD-0020400-0B	SENSOR	センサー	(1)
37		SM-6020450-TP	SCREW	平ねじ	2
38		400-72110	THREAD HOLD MOTOR INSTALLING P	糸掴みモーター取付板	1
39		GBR-0118500A	WASHER	補助ワッシャー	1
		NOTE(注記)	#01....TYPE H	H仕様	

14. X-Y COMPONENTS (1)(FOR 4530)
 X - Y 關係 (1) (4530用)

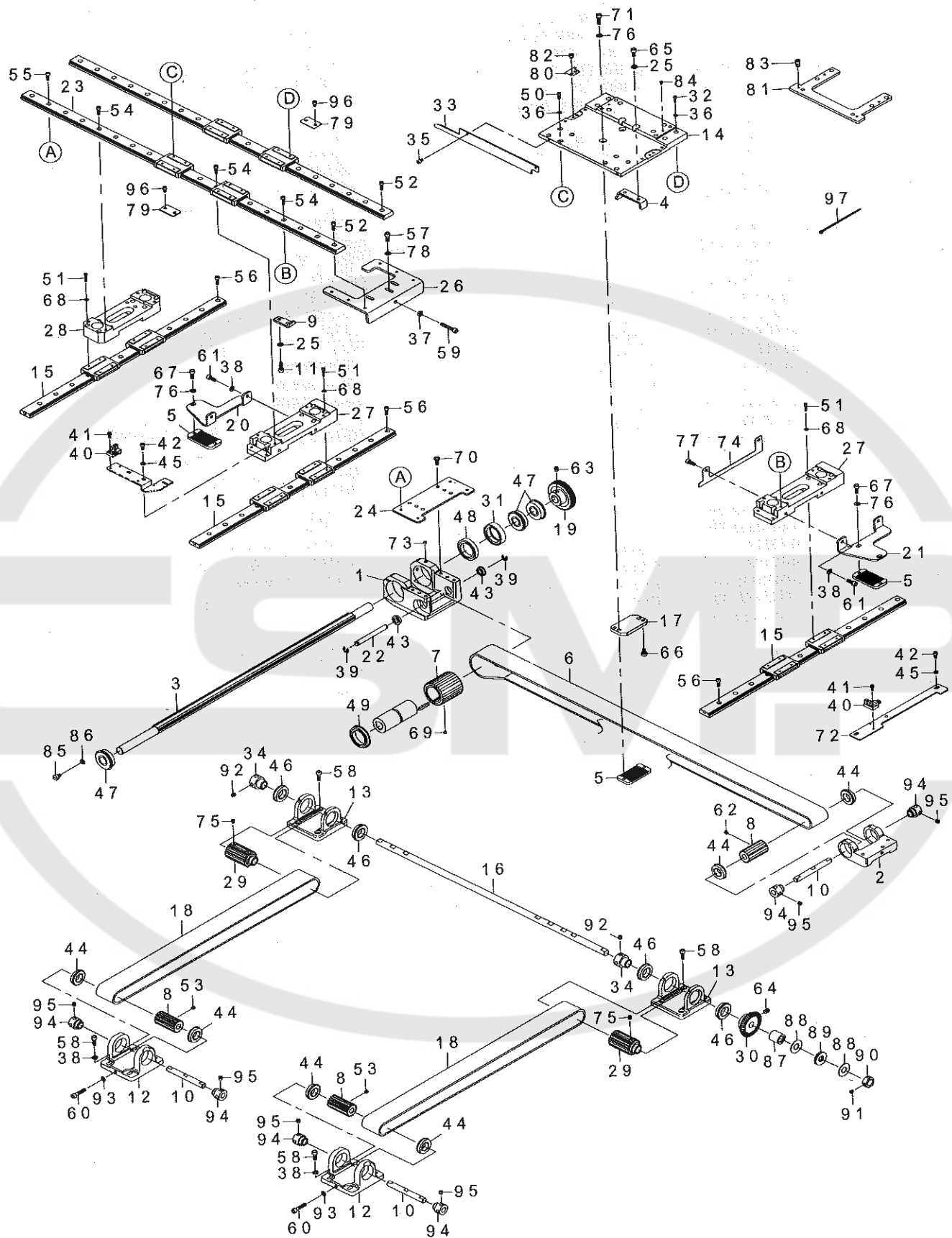

REF.NO	NOTE	PART NO	DESCRIPTION	品名	Qty
1		400-72160	X_DRIVE_BRACKET	X 駆動ブラケット	1
2		400-72113	X DRIVEN BRACKET	X 従動ブラケット	1
3		400-72115	X DRIVE SPLINE SHAFT	X 駆動スプライン軸	1
4		400-72130	X STOPPER A 4530	X ストップ A 4530	1
5		400-72166	BELT RECEIVER	ベルト押え	3
6		400-72169	X TIMING BELT(4530)	X タイミングベルト (4530)	1
7		400-72167	X DRIVE SPROCKET	X 駆動スプロケット	1
8		400-72168	DRIVEN SPROCKET	従動スプロケット	3
9		400-72152	X STOPPER B 4530	X ストップ B 4530	1
10		400-72226	DRIVEN SHAFT	従動軸	3
11	*	SM-6051402-TP	SCREW M5X0.8 L=14	六角穴ボルト	2
12		400-72114	Y DRIVEN BRACKET	Y 従動ブラケット	2
13		400-72112	Y DRIVE BRACKET	Y 駆動ブラケット	2
14		400-72116	X FEED BASE	X 移動ベース	1
15		400-72117	Y-LM GUIDE	Y-LMガイド	3
16		400-72118	Y DRIVE SHAFT	Y 駆動軸	1
17		400-72119	X BELT PRESSER FIX PLATE	X ベルト押え取付板	1
18		400-72171	Y TIMING BELT	Y タイミングベルト	2
19		B2534-223-C00	X DRIVEN WHEEL	X 従動歯車	1
20		400-72129	Y BELT PRESSER FIX PLATE LEFT	Y ベルト押え取付板左	1
21		400-72128	Y BELT PRESSER FIX PLATE RIGHT	Y ベルト押え取付板右	1
22		B2539-223-C00	X IDLER SHAFT	X アイドラ軸	1
23		400-72120	X-LM GUIDE(4530)	X-LMガイド (4530)	2
24		400-72122	X DRIVE BRACKET BASE	X 駆動ブラケットベース	1
25		WP-0531000-SD	WASHER M5	平座金小形丸 M5	4
26		400-72156	X DRIVEN BRACKET BASE 4530	X 従動ブラケットベース4530	1
27		400-72124	Y FEED BASE A	Y 移動ベース A	2
28		400-72125	Y FEED BASE B	Y 移動ベース B	1
29		400-72126	Y DRIVE SPROCKET	Y 駆動スプロケット	2
30		B2548-223-C00	Y DRIVEN WHEEL	Y 従動歯車	1
31		B2549-223-C00	COLLAR	X 駆動軸ベアリングカラー	1
32		SM-6031002-TP	HEXAGONAL BOLT M3 X 10	六角穴ボルト M3 X 0.5 L=10	8
33		400-72131	X SLIT PLATE 4530	X 方向スリット板4530	1
34		236-18606	BEARING SUPPORT	上下軸前ベアリング受	2
35		SM-6040602-TP	SCREW M4 L=6	六角穴ボルト M4 X 0.7 L=6	2
36		WP-0320501-SD	WASHER	平座金みがき丸 M3	16
37		NM-6050001-SP	NUT M5	六角ナット M5 X 0.8 1種	1
38		WP-0531000-SD	WASHER M5	平座金小形丸 M5	12
39		RE-0600000-K0	E-RING 6	E 形止め輪 6	2
40		HD-0005700-0A	PHOTO SENSOR	フォトセンサー	2
41		SL-4031091-SC	SCREW M3 X 10	なべねじセムス	2
42		SM-6040802-TP	SCREW M4X0.7 L=8	六角穴ボルト	4
43		SB-1080005-00	RADIAL BEARING	ラジアル軸受	2
44		SB-1150006-00	BALL BEARING	ころがり軸受	6
45		WP-0430800-SD	WASHER M4	平座金小形丸 M4	4
46		SB-1170009-00	BEARING	ころがり軸受	4
47		B1802-180-000	BUSHING, FRONT	駆動軸前メタル	3
48		SB-1300002-00	BEARING	ころがり軸受	1
49		SB-1300003-00	BEARING	ころがり軸受	1
50		SM-6030602-TP	SCREW M3X0.5 L=6	六角穴ボルト M3 X 0.5 L=6	8
51		SM-6031402-TP	SCREW	六角穴ボルト	24
52		SM-6041202-TP	SCREW M4X0.7 L=12	六角穴ボルト	6
53		SM-8050412-TP	SCREW M5 L=4	止めねじ M5 L=4	4
54		SM-6041202-TP	SCREW M4X0.7 L=12	六角穴ボルト	12
55		SM-6041202-TP	SCREW M4X0.7 L=12	六角穴ボルト	4
56		SM-6041202-TP	SCREW M4X0.7 L=12	六角穴ボルト	21
57		SM-6051202-TP	SCREW M5X0.8 L=12	六角穴ボルト M5 X 0.8 L=12	3
58		SM-6051402-TP	SCREW M5X0.8 L=14	六角穴ボルト	16
59	*	SM-6053052-TN	SCREW	六角穴ボルト M5 L=30	1
60		SM-6052502-TP	SCREW M5X0.8 L=25	六角穴ボルト	2
61		SM-6051202-TP	SCREW M5X0.8 L=12	六角穴ボルト M5 X 0.8 L=12	4
62		SM-8050412-TP	SCREW M5 L=4	止めねじ M5 L=4	2
63		SM-8060802-TP	SCREW M6 L=8	止めねじ M6 L=8	2
64		SM-8060812-TP	SCREW M6 L=8	止めねじ M6 L=8	2
65		SM-6051002-TP	SCREW M5X0.8 L=10	六角穴ボルト M5 X 0.8 L=10	2
66		SM-6050800-SP	SCREW M5 L=8	平ねじ M5 L=8	2
67		SM-6051202-TP	SCREW M5X0.8 L=12	六角穴ボルト M5 X 0.8 L=12	4
68		WP-0320501-SD	WASHER	平座金みがき丸 M3	24
69		SM-8050412-TP	SCREW M5 L=4	止めねじ M5 L=4	2
70		SM-4051255-SP	SCREW M5 L=12	なべねじ M5 L=12	6
71		SM-6051602-TP	SCREW M5X0.8 L=16	六角穴ボルト M5 X 0.8 L=16	2
72		400-72209	YSENSOR INSTALLING PLATE	Y センサー取付板	1
73		SM-8050412-TP	SCREW M5 L=4	止めねじ M5 L=4	2
74		400-72133	Y SLIT PLATE	Y 方向スリット板	1
75		SM-8050612-TP	SCREW M5X6	止めねじ M5 X 0.8 L=6	8
76		WP-0531000-SD	WASHER M5	平座金小形丸 M5	6
77		SM-6050652-TP	HEXAGON SOCKET HEAD SCREW M5X6	六角穴付きボルト	2
78		WP-0531000-SD	WASHER M5	平座金小形丸 M5	3
79		B4022-221-D00	FLAT CABLE CLAMP	フラットケーブルクランプ	2
80		B1158-224-C00	COVER PRESSER	補助カバー押え	2
81		400-72127	LOWER PLATE INSTALLING PLATE	下板取付板	1
82		SM-6040450-TP	SCREW M4 L=4	ねじ M4 L=4	4
83		B1519-026-00G	HINGE STUD	ヒンジ軸	2
84		B1816-280-000	GUIDE PIN	中蓋押えガイドピン	2
85		SM-6050800-SP	SCREW M5 L=8	平ねじ M5 L=8	1
86		WP-0531000-SD	WASHER M5	平座金小形丸 M5	1
87		SB-3120006-00	BEARING	ころがり軸受	1
88		138-87005	THRUST WASHER	スラスト座金	2
89		SB-6120001-00	BEARING	ころがり軸受	1
90		CS-1200981-TP	THRUST COLLAR D=12 W=9	スラスト受 D=12 W=9	1
91		SM-8050592-TP	SCREW	止めねじ M5 L=5	2
92		SS-8660512-TP	SCREW 1/4-40 L=5	止めねじ 1/4-40 L=5	4
93		WP-0531000-SD	WASHER M5	平座金小形丸 M5	2
94		400-72227	BEARING_BUSH	ベアリングブッシュ	6
95		SM-8060552-TP	SCREW M6 L=5	止めねじ	12
96		SM-6040602-TP	SCREW M4 L=6	六角穴ボルト M4 X 0.7 L=6	4
97		EA-9500B01-00	CABLE BAND	束線バンド	3

15. X-Y COMPONENTS (2)(FOR 6030)
 X - Y 關係 (2) (6030用)

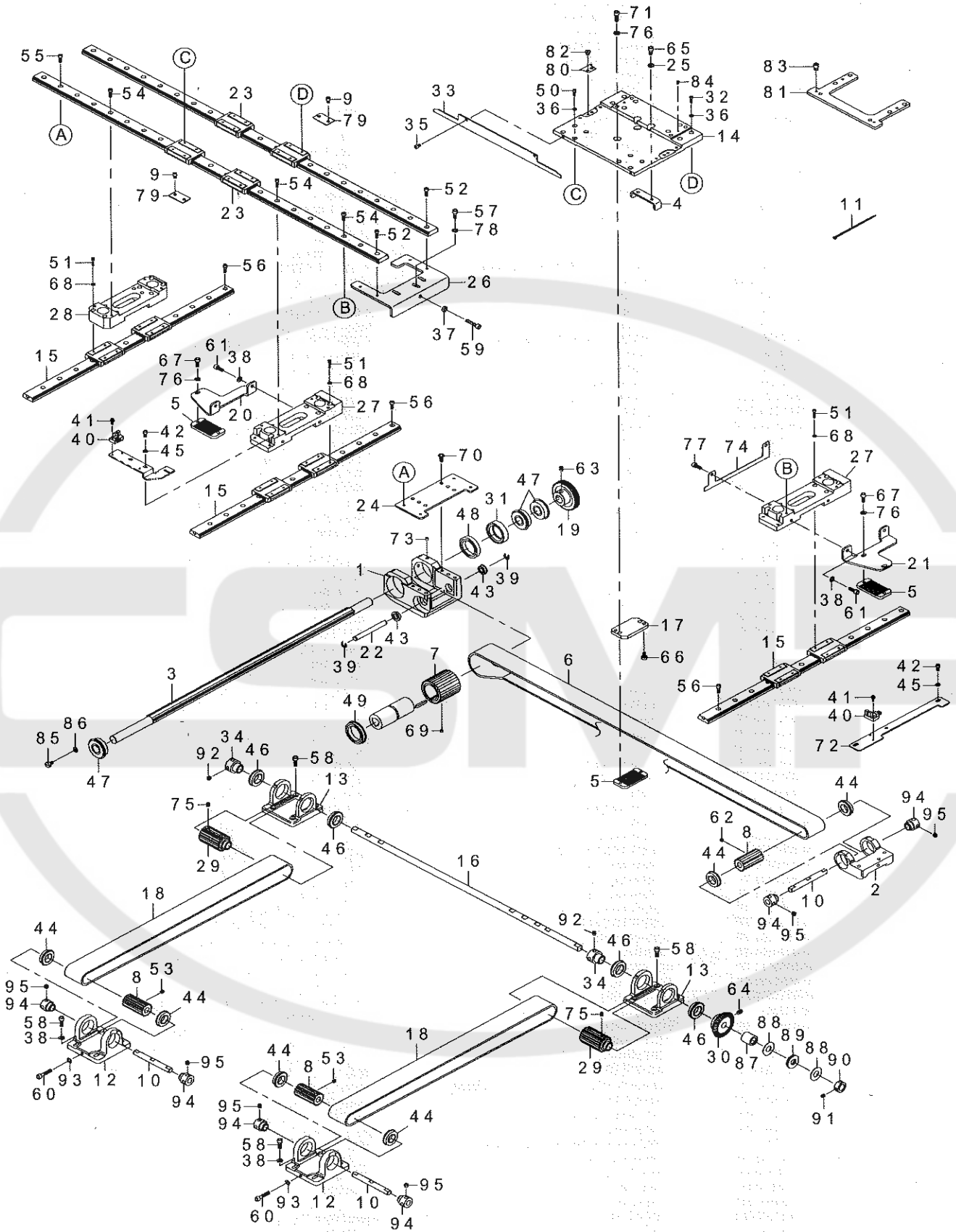

REF.NO	NOTE	PART NO	DESCRIPTION	品名	Qty
1		400-72160	X_DRIVE_BRACKET	X 駆動ブラケット	1
2		400-72113	X_DRIVEN_BRACKET	X 従動ブラケット	1
3		400-72115	X_DRIVE_SPLINE_SHAFT	X 駆動スプライン軸	1
4		400-72153	X_STOPPER_6030	X ストップバ6030	1
5		400-72166	BELT_RECEIVER	ベルト押え	3
6		400-72170	X_TIMING_BELT(6030)	X タイミングベルト (6030)	1
7		400-72167	X_DRIVE_SPROCKET	X 駆動スプロケット	1
8		400-72168	DRIVEN_SPROCKET	従動スプロケット	3
9		SM-6040602-TP	SCREW M4 L=6	六角穴ボルト M4 X 0.7 L=6	4
10		400-72226	DRIVEN_SHAFT	従動軸	3
11		EA-9500B01-00	CABLE_BAND	束線バンド	3
12		400-72114	Y_DRIVEN_BRACKET	Y 従動ブラケット	2
13		400-72112	Y_DRIVE_BRACKET	Y 駆動ブラケット	2
14		400-72116	X_FEED_BASE	X 移動ベース	1
15		400-72117	Y-LM_GUIDE	Y-LMガイド	4
16		400-72118	Y_DRIVE_SHAFT	Y 駆動軸	1
17		400-72119	X_BELT_PRESSER_FIX_PLATE	X ベルト押え取付板	1
18		400-72171	Y_TIMING_BELT	Y タイミングベルト	2
19		B2534-223-C00	X_DRIVEN_WHEEL	X 従動歯車	1
20		400-72129	Y_BELT_PRESSER_FIX_PLATE_LEFT	Y ベルト押え取付板左	1
21		400-72128	Y_BELT_PRESSER_FIX_PLATE_RIGHT	Y ベルト押え取付板右	1
22		B2539-223-C00	X_IDLER_SHAFT	X アイドラー軸	1
23		400-72121	X-LM_GUIDE(6030)	X-LMガイド (6030)	2
24		400-72122	X_DRIVE_BRACKET_BASE	X 駆動ブラケットベース	1
25		WP-0531000-SD	WASHER M5	平座金小形丸 M5	2
26		400-72123	X_DRIVEN_BRACKET_BASE(6030)	X 従動ブラケットベース (6030)	1
27		400-72124	Y_FEED_BASE_A	Y 移動ベース A	2
28		400-72125	Y_FEED_BASE_B	Y 移動ベース B	2
29		400-72126	Y_DRIVE_SPROCKET	Y 駆動スプロケット	2
30		B2548-223-C00	Y_DRIVEN_WHEEL	Y 従動歯車	1
31		B2549-223-C00	COLLAR	X 駆動軸ベアリングカラー	1
32		SM-6031002-TP	HEXAGONAL_BOLT M3 X 10	六角穴ボルト M3 X 0.5 L=10	8
33		400-72132	X_SLIT_PLATE_6030	X 方向スリット板6030	1
34		236-18606	BEARING_SUPPORT	上下軸前ベアリング受け	2
35		SM-6040602-TP	SCREW M4 L=6	六角穴ボルト M4 X 0.7 L=6	2
36		WP-0320501-SD	WASHER	平座金みがき丸 M3	16
37		NM-6050001-SP	NUT M5	六角ナット M5 X 0.8 1種	1
38		WP-0531000-SD	WASHER M5	平座金小形丸 M5	12
39		RE-0600000-K0	E-RING 6	E 形止め輪 6	2
40		HD-0005700-OA	PHOTO_SENSOR	フォトセンサー	2
41		SL-4031091-SC	SCREW M3 X 10	なべ小ねじセムス	2
42		SM-6040802-TP	SCREW M4X0.7 L=8	六角穴ボルト	4
43		SB-1080005-00	RADIAL_BEARING	ラジアル軸受	2
44		SB-1150006-00	BALL_BEARING	ころがり軸受	6
45		WP-0430800-SD	WASHER M4	平座金小形丸 M4	4
46		SB-1170009-00	BEARING	ころがり軸受	4
47		B1802-180-000	BUSHING_FRONT	駆動軸前メタル	1
48		SB-1300002-00	BEARING	ころがり軸受	3
49		SB-1300003-00	BEARING	ころがり軸受	1
50		SM-6030602-TP	SCREW M3X0.5 L=6	六角穴ボルト M3 X 0.5 L=6	8
51		SM-6031402-TP	SCREW	六角穴ボルト	32
52		SM-6041202-TP	SCREW M4X0.7 L=12	六角穴ボルト	4
53		SM-8050412-TP	SCREW M5 L=4	止めねじ M5 L=4	4
54		SM-6041202-TP	SCREW M4X0.7 L=12	六角穴ボルト	12
55		SM-6041202-TP	SCREW M4X0.7 L=12	六角穴ボルト	4
56		SM-6041202-TP	SCREW M4X0.7 L=12	六角穴ボルト	28
57		SM-6051202-TP	SCREW M5X0.8 L=12	六角穴ボルト M5 X 0.8 L=12	3
58		SM-6051402-TP	SCREW M5X0.8 L=14	六角穴ボルト	16
59		SM-6052502-TP	SCREW M5X0.8 L=25	六角穴ボルト	1
60		SM-6052502-TP	SCREW M5X0.8 L=25	六角穴ボルト	2
61		SM-6051202-TP	SCREW M5X0.8 L=12	六角穴ボルト M5 X 0.8 L=12	4
62		SM-8050412-TP	SCREW M5 L=4	止めねじ M5 L=4	2
63		SM-8060802-TP	SCREW M6 L=8	止めねじ M6 L=8	2
64		SM-8060812-TP	SCREW M6 L=8	止めねじ M6 L=8	2
65		SM-8051002-TP	SCREW M5X0.8 L=10	六角穴ボルト M5 X 0.8 L=10	2
66		SM-6050800-SP	SCREW M5 L=8	平ねじ M5 L=8	2
67		SM-6051202-TP	SCREW M5X0.8 L=12	六角穴ボルト M5 X 0.8 L=12	4
68		WP-0320501-SD	WASHER	平座金みがき丸 M3	32
69		SM-8050412-TP	SCREW M5 L=4	止めねじ M5 L=4	2
70		SM-4051255-SP	SCREW M5 L=12	なべねじ M5 L=12	6
71		SM-6051602-TP	SCREW M5X0.8 L=16	六角穴ボルト M5 X 0.8 L=16	2
72		400-72209	YSENSOR_INSTALLING_PLATE	Y センサー取付板	1
73		SM-8050412-TP	SCREW M5 L=4	止めねじ M5 L=4	2
74		400-72133	Y_SLIT_PLATE	Y 方向スリット板	1
75		SM-8050612-TP	SCREW M5X6	止めねじ M5 X 0.8 L=6	8
76		WP-0531000-SD	WASHER M5	平座金小形丸 M5	6
77		SM-6050652-TP	HEXAGON_SOCKET_HEAD_SCREW M5X6	六角穴付きボルト	2
78		WP-0531000-SD	WASHER M5	平座金小形丸 M5	3
79		B4022-221-D00	FLAT_CABLE_CLAMP	フラットケーブルクランプ	2
80		B1158-224-C00	COVER_PRESSER	補助カバー押え	2
81		400-72127	LOWER_PLATE_INSTALLING_PLATE	下板取付板	1
82		SM-6040450-TP	SCREW M4 L=4	ねじ M4 L=4	4
83		B1519-026-00G	HINGE_STUD	ヒンジ軸	2
84		B1816-280-000	GUIDE_PIN	中釜押えガイドピン	2
85		SM-6050800-SP	SCREW M5 L=8	平ねじ M5 L=8	1
86		WP-0531000-SD	WASHER M5	平座金小形丸 M5	1
87		SB-3120006-00	BEARING	ころがり軸受	1
88		138-87005	THRUST_WASHER	スラスト座金	2
89		SB-6120001-00	BEARING	ころがり軸受	1
90		CS-1200981-TP	THRUST_COLLAR D=12 W=9	スラスト受 D=12 W=9	1
91		SM-8050592-TP	SCREW	止めねじ M5 L=5	2
92		SS-8660512-TP	SCREW 1/4-40 L=5	止めねじ 1/4-40 L=5	4
93		WP-0531000-SD	WASHER M5	平座金小形丸 M5	2
94		400-72227	BEARING_BUSH	ベアリングブッシュ	6
95		SM-8060552-TP	SCREW M6 L=5	止めねじ	12

16. X-Y COMPONENTS (3)
X - Y 關係 (3)

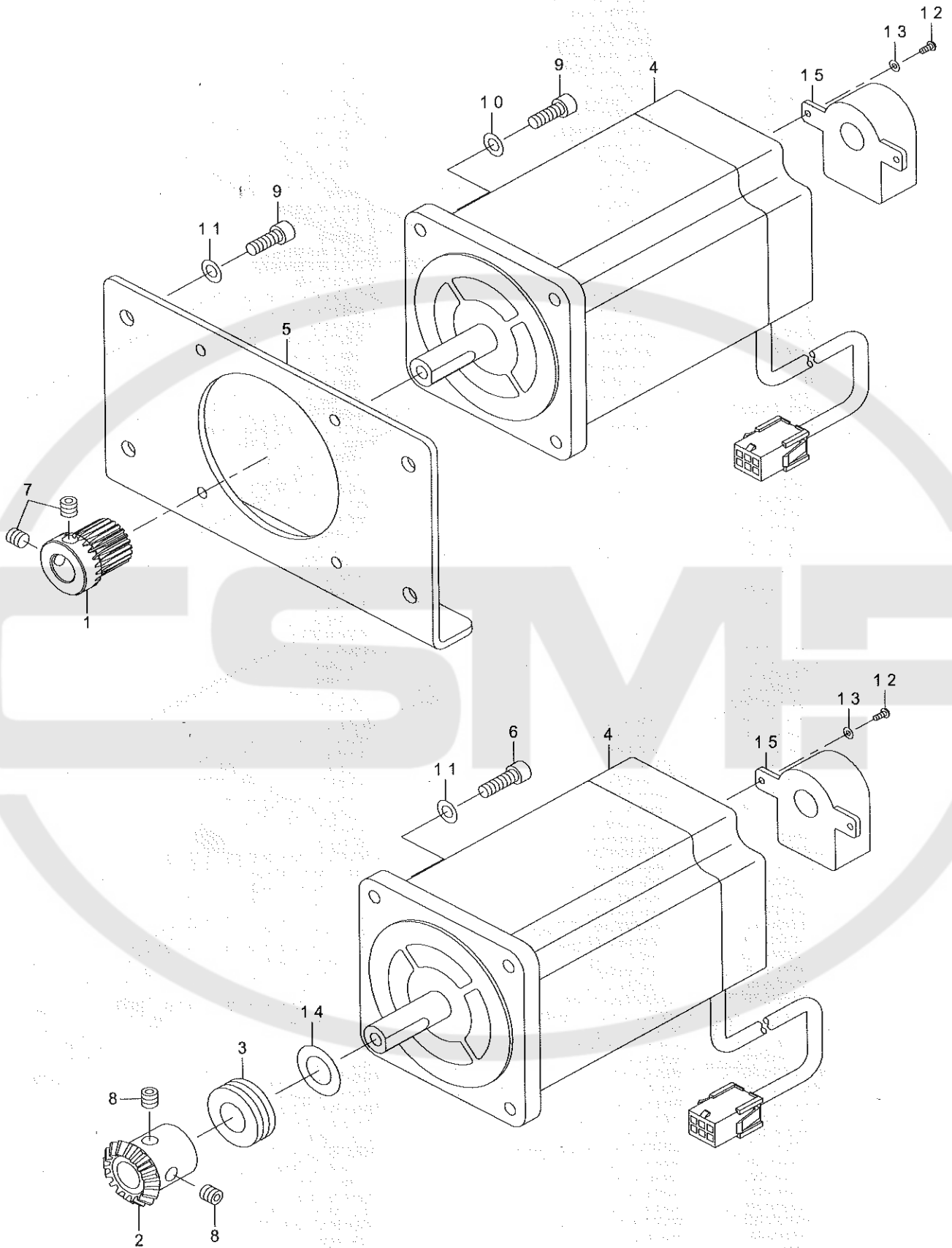

REF.NO	NOTE	PART NO	DESCRIPTION	品名	Qty
1		B2525-223-C00	X DRIVE WHEEL	X 駆動歯車	1
2		B2526-223-C00	Y DRIVE WHEEL	Y 駆動歯車	1
3		SB-4120001-00	BEARING	ころがり軸受	1
4		400-71945	STEPPING MOTOR	ステッピングモータ	2
5		400-72155	X MOTOR INSTALLING PLATE	X モータ取付板	1
6		SM-6051602-TP	SCREW M5X0.8 L=16	六角穴ボルト M5 X 0.8 L=16	4
7		SM-8060602-TP	SCREW M6X6	止めねじ M6 L=6	2
8		SM-8060602-TP	SCREW M6X6	止めねじ M6 L=6	2
9		SM-6051402-TP	SCREW M5X0.8 L=14	六角穴ボルト	8
10		WP-0531000-SD	WASHER M5	平座金小形丸 M5	4
11		WP-0531000-SD	WASHER M5	平座金小形丸 M5	8
12		SM-4020501-SC	SCREW M2 L=5	なべ小ねじ M2 L=5	4
13		WP-0220301-SC	WASHER M2	平座金みがき丸 M2	4
14		B2537-221-D00	Y DRIVE WHEEL SPACER	Y 駆動歯車スペーサ	3
15		HD-0027800-00	SENSOR	センサー	2



17. CLOTH FEED MECHANISM COMPONENTS

布送り台関係

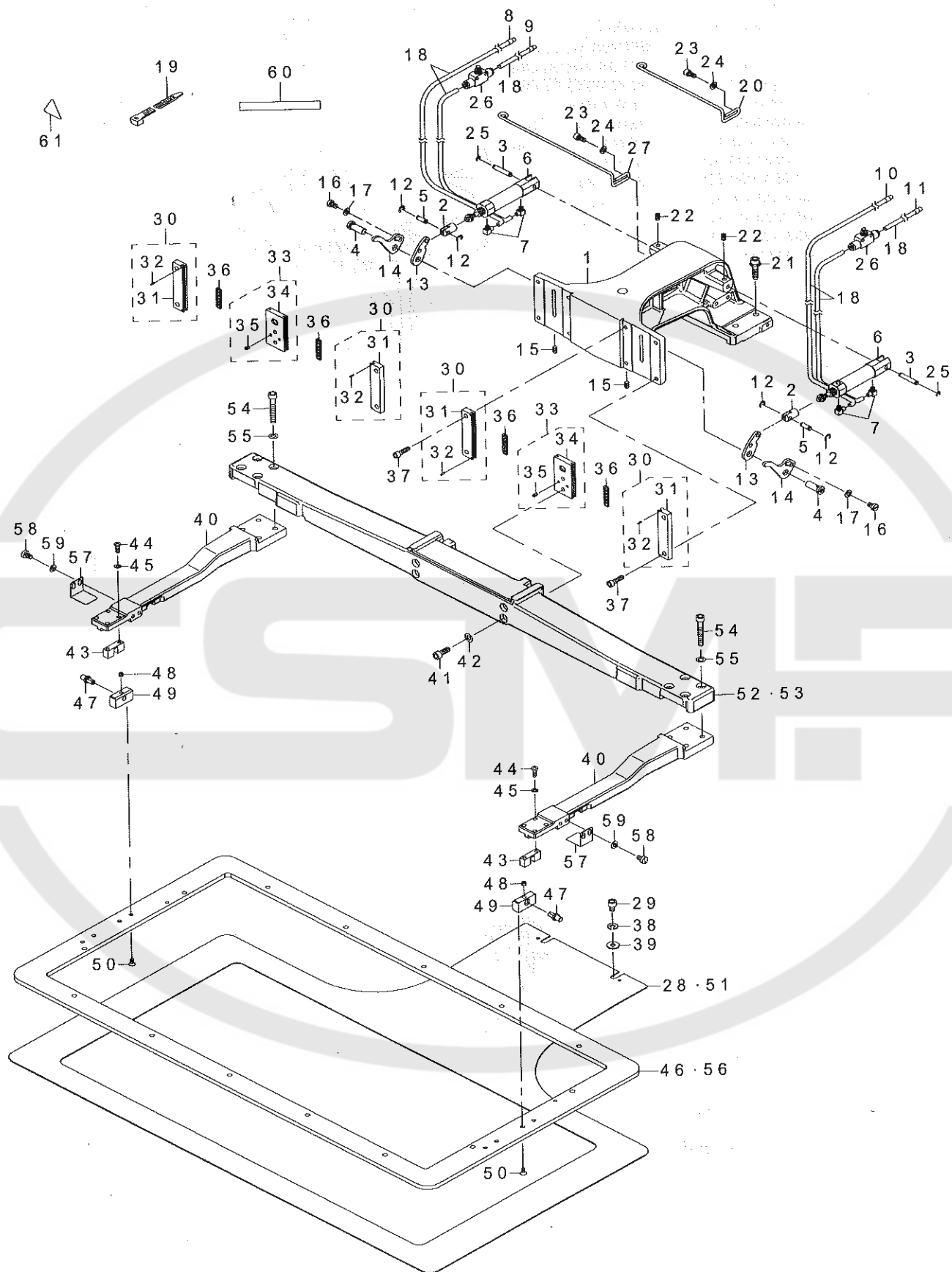

REF.NO	NOTE	PART NO	DESCRIPTION	品名	Qty
1		400-72135	CLOTH FEED BASE	布送り台	1
2		400-23644	CYLINDER KNUCKLE	押えシリンダナックル	2
3		B1504-210-000	CONNECTING SHAFT	ソレノイド連結軸	2
4		260-23408	FEED STUD	送り軸	2
5		400-23635	CYLINDER PIN	シリンダ接続ピン	2
6		PA-1602509-A0	AIR CYLINDER	エアシリンダ	2
7		PJ-0460525-03	HOSE ELBOW	ホース エルボ	4
8		B4711-220-00C	AIR TUBE LABEL J03 LEFT	エアチューブラベル J 03 L	1
9		B4711-220-00D	AIR TUBE LABEL J04 LEFT	エアチューブラベル J 04 L	1
10		B4711-220-00G	AIR TUBE LABEL J03 RIGHT	エアチューブラベル J 03 R	1
11		B4711-220-00H	AIR TUBE LABEL J04 RIGHT	エアチューブラベル J 04 R	1
12		RE-0300000-K0	E-RING 3	E形止め輪 3	4
13		400-32229	LIFTING_LEVER_A	布押えレバー A	2
14		400-32230	LIFTING_LEVER_B	布押えレバー B	2
15		SM-8050812-TP	SCREW M5X8	止めねじ M5 X 0.8 L=8	2
16		SM-6050800-SP	SCREW M5 L=8	平ねじ M5 L=8	2
17		WP-0531000-SD	WASHER M5	平座金小形丸 M5	2
18		BT-0400251-EB	URETHANE HOSE, BLACK	ウレタンホース 黒	4
19		HX-0023300-00	CLIP	束線バンド	10
20		B2568-223-C00	AIR TUBE SUPPORT	エアチューブ支え	1
21		SL-6062592-TN	SCREW	座金付き六角穴ボルト	4
22		SM-8050812-TP	SCREW M5X8	止めねじ M5 X 0.8 L=8	2
23		SM-6051002-TP	SCREW M5X0.8 L=10	六角穴ボルト M5 X 0.8 L=10	4
24		WP-0531000-SD	WASHER M5	平座金小形丸 M5	4
25		RE-0320000-K0	E-RING 3.2	E形止め輪 3.2	2
26		PC-0124010-00	SPEED CONTROLLER	スピードコントローラ	2
27		B2568-224-C00	AIR TUBE SUPPORT A	エアチューブ支え A	1
28	#01	400-72136	LOWER PLATE 4530	下板 4530	1
29		SM-6060802-TP	SCREW M6 L=8	六角穴ボルト M6 L=8	2
30		B2567-223-CA0	WORK CLAMP FOOT PLATE B ASM.	布押え滑り板 B組	4
31		B2567-223-C00	WORK CLAMP FOOT PLATE B	布押え滑り板 B	(4)
32		PS-0150065-KP	SPRING PIN 1.5X6	スプリングピン 1.5 X 6	(8)
33		B2611-223-CA0	SLIDE PLATE ASM.	布押え脚滑り板組	2
34		B2611-223-C00	WORK CLAMP FOOT SLIDE PLATE	布押え脚滑り板	(2)
35		B1816-280-000	GUIDE PIN	中釜押えガイドピン	(4)
36		B2569-229-000	SLIDING PLATE BEARING	滑り板ベアリング	4
37		SM-6051802-TP	SCREW M5 L=18	六角穴ボルト	8
38		WS-0610002-KP	SPRING WASHER	ばね座金	2
39		WP-0611626-SP	WASHER 15X6X1.6	平座金	2
40		400-72163	FEEDING_FRAME_ARM_B	布押え外枠腕 B	2
41		SS-6151612-TP	SCREW	六角穴ボルト	4
42		WP-0641600-SC	WASHEW 6.4X12.5X1.6	平座金	4
43		400-51770	FEEDING FRAME BALL CATCH	外枠ボールキャッチ	2
44		SM-4041255-SP	SCREW M4 L=12	なべ小ねじ M4 L=12	4
45		WP-0430800-SD	WASHER M4	平座金小形丸 M4	4
46	#01	400-72138	FEEDING FRAME 4530	布押え外枠4530	1
47		B2560-220-000	SUPPORT PIN	外枠支え軸	2
48		SM-8050412-TP	SCREW M5 L=4	止めねじ M5 L=4	2
49		400-51769	FEEDING FRAME SUPPORT BEARING	外枠支え軸受	2
50		SM-1040870-TP	SCREW	皿小ねじ M4 L=8	4
51	#02	400-72137	LOWER PLATE 6030	下板 6030	1
52	#01	400-72161	FEEDING_FRAME_ARM_A_4530	布押え外枠腕 A_4530	1
53	#02	400-72162	FEEDING_FRAME_ARM_A_6030	布押え外枠腕 A_6030	1
54		SM-6062502-TN	HEXAGONAL-HOLE BOLT	六角穴ボルト	8
55		WP-0641600-SC	WASHEW 6.4X12.5X1.6	平座金	8
56	#02	400-72139	FEEDING FRAME 6030	布押え外枠6030	1
57		B2563-215-000	FEEDING FRAME HOLDING PLATE	外枠受け板	2
58		SM-6050800-SP	SCREW M5 L=8	平ねじ M5 L=8	4
59		WP-0531000-SD	WASHER M5	平座金小形丸 M5	4
60		HX-0036400-0E	PARTS	束線パーツ	1.2
61	* #02	CM-3002000-03	ATTENTION LABEL	指げが注意シール (31.5)	1
		NOTE(注記)	#01.....FOR AMS-224E-4530	AMS-224E-4530用	
			#02.....FOR AMS-224E-6030	AMS-224E-6030用	

18. PNEUMATIC COMPONENTS

エア関係

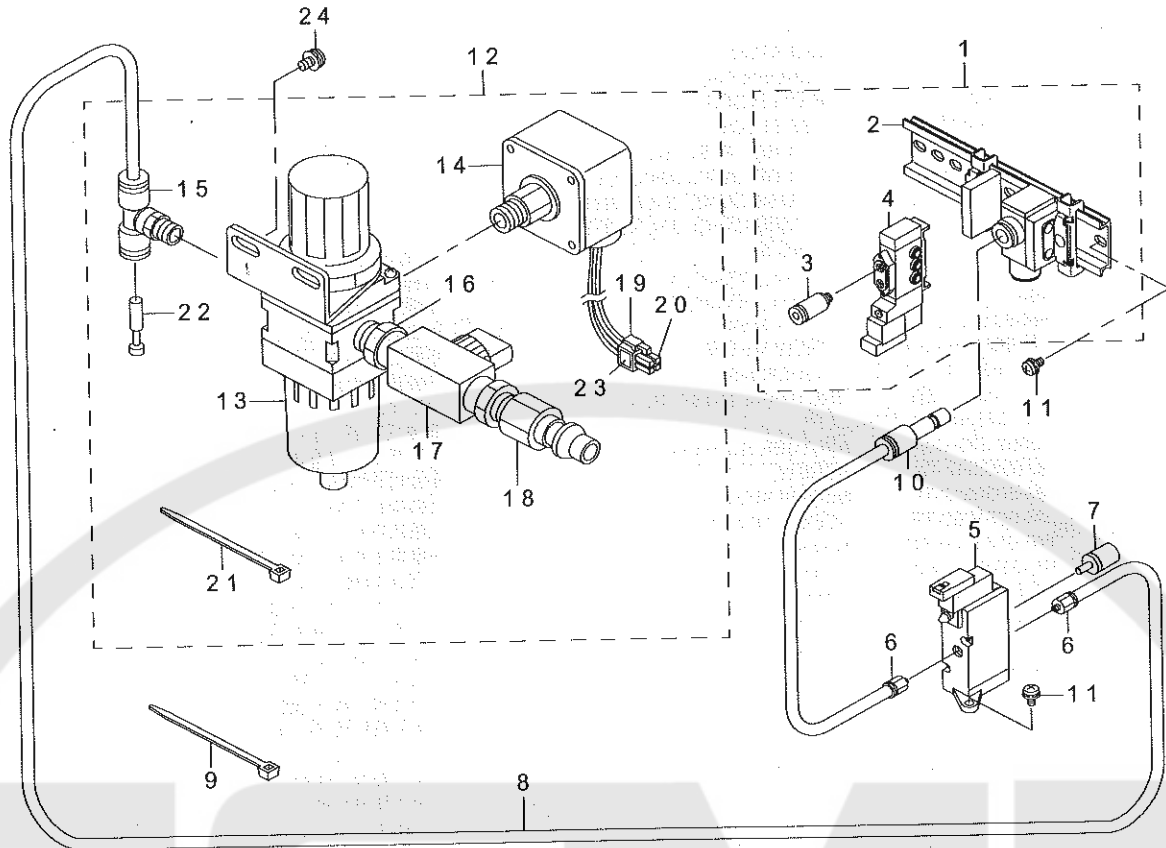

REF.NO	NOTE	PART NO	DESCRIPTION	品名	Qty
1		400-72220	SOLENOID_VALVE_ASM	電磁弁組	1
2		PV-9150050-00	SOLENOID VALVE INSTALLING BASE	電磁弁取付ベース	(1)
3		PJ-3010405-05	HALF UNION	ハーフユニオン	(2)
4		PV-1502091-00	SOLENOID VALVE	電磁弁	(1)
5		PV-1351270-A0	3-WAY SOLENOID VALVE	3ポート電磁切替弁	1
6		PJ-3010651-03	HALF UNION 6XPT1/8	ハーフユニオン	2
7		PX-0551040-00	SILENCER (PT1/8)	サイレンサ	1
8		BT-0600401-EB	TUBE	チューブ	1.1
9		EA-9500B01-00	CABLE BAND	束線バンド	1
10		PJ-3010600-03	REDUCER	レデューサ	1
11		SL-4040891-SC	SCREW M4 L=8	座金付きなべ小ねじ M4 L=8	4
12		B4715-215-0A0	FILTER REGULATOR ASM.	フィルタレギュレータ組	1
13		PF-0552040-B0	FILTER REGULATOR	フィルタレギュレータ	(1)
14		G8124-270-000	AIR PRESSUE SWITCH	圧力スイッチ	(1)
15		PJ-3050652-02	TEE	両口ティ	(1)
16		PJ-0305200-01	RING JOINT (NIPPLE)	管継ぎ手 (ニップル)	(1)
17		G5430-116-000	AIR COCK	エアコック	(1)
18		PJ-3090052-03	QUICK JOINT PLUG	ワンタッチジョイントプラグ	(1)
19		HK-0346100-40	HOUSING	ハウジング	(1)
20		HK-0346400-00	PIN CONTACT	ピン ターミナル	(3)
21		EA-9500B01-00	CABLE BAND	束線バンド	(5)
22		PX-9500090-00	PLUG	プラグ	(1)
23		E2678-453-000	CONNECTOR MARKER J78	コネクタマーカ J78	(1)
24		SL-4051091-SC	SCREW M5X0.8 L=10	なべ小ねじセムス M5 X 0.8 L=10	2

19. THREAD STAND COMPONENTS

糸立て装置関係

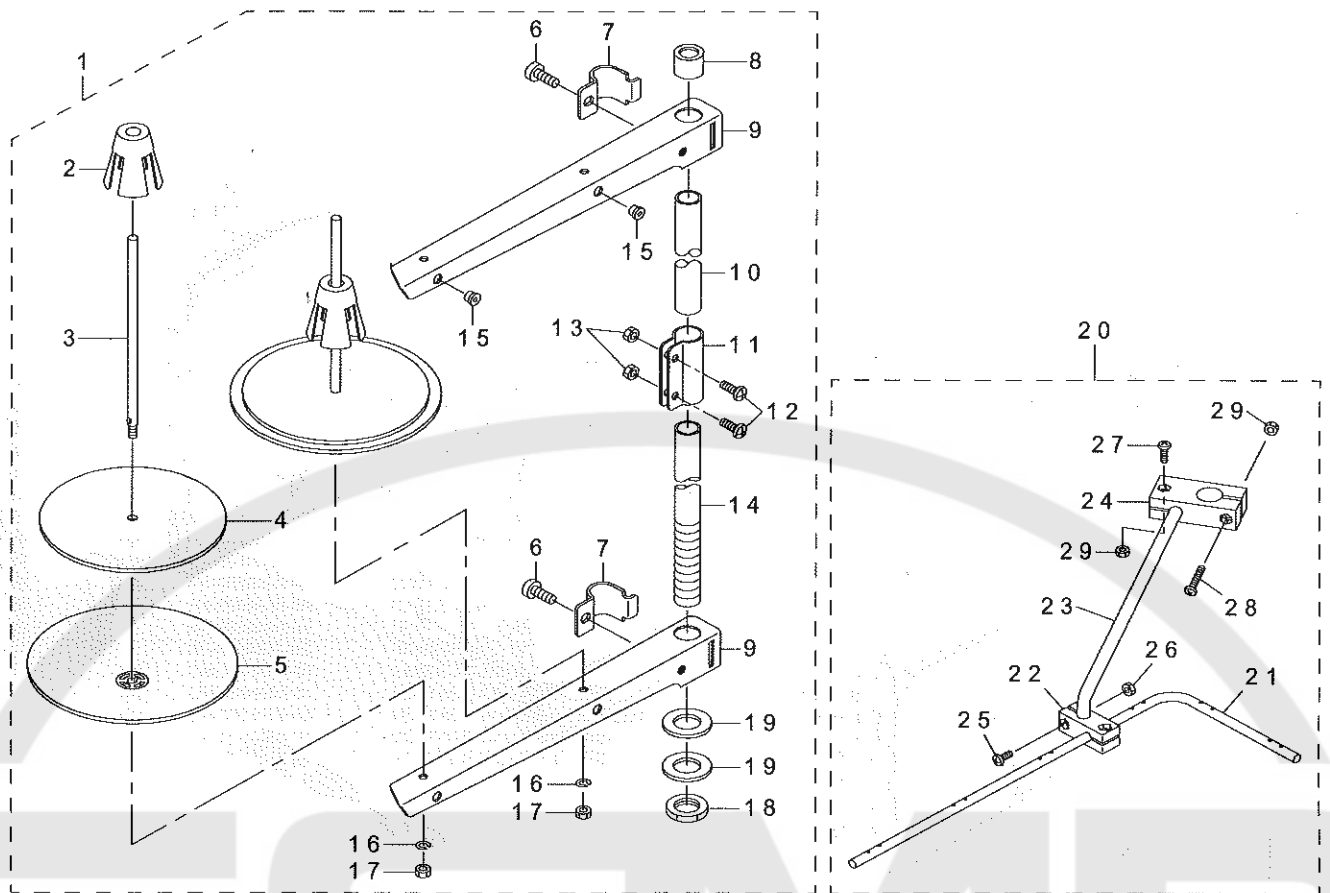

REF.NO	NOTE	PART NO	DESCRIPTION	品名	Qty
1		229-30358	THREAD STAND ASM.	糸立て装置組	1
2		229-31109	SPOOL RETAINER	糸巻き振れ止め	(2)
3		229-31000	SPOOL PIN	糸巻き受け棒	(2)
4		229-30903	SPOOL REST CUSHION	糸巻き受け皿クッション	(2)
5		229-30804	SPOOL REST	糸巻き受け皿	(2)
6		SM-6061610-SC	SCREW M6 L=16	平小ねじ M6 L=16	(2)
7		229-30705	THREAD GUIDE ARM JOINT	糸立て棒締め金具	(2)
8		229-31406	SPOOL REST ROD RUBBER CAP	糸立て棒保護ゴム	(1)
9		229-30507	SPOOL REST ARM	糸立て腕	(2)
10		229-30408	SPOOL REST ROD, UPPER	糸立て棒(上)	(1)
11		229-31307	SPOOL REST ROD JOINT	糸立て棒継ぎ手	(1)
12		SM-4051405-SE	SCREW M5 L=14	なべ小ねじ M5 L=14	(2)
13		NM-6050001-SE	NUT M5	六角ナット M5	(2)
14		229-30309	SPOOL REST ROD, LOWER	糸立て棒(下)	(1)
15		229-31208	THREAD GUIDE	糸道	(2)
16		WS-0510002-KN	SPRING WASHER	ばね座金 5.1 X 9.2 X 1.3	(2)
17		NM-6050001-SE	NUT M5	六角ナット M5	(2)
18		NM-6160511-SE	NUT M16X1.5	六角ナット M16 X 1.5 1種	(1)
19		WP-1702600-S0	WASHER 17X30X2.6	平座金 17 X 30 X 2.6	(2)
20	*	269-10059	THREAD GUIDE ARM ASM.	糸立て糸案内(組)	1
21		131-67903	THREAD STANDING THREAD GUIDE	糸立て糸案内	(1)
22		131-68000	THREAD GUIDE BASE, LOWER	糸立て糸案内(下)台	(1)
23		131-68109	THREAD GUIDE ARM BASE	糸立て糸案内腕	(1)
24		131-68208	THREAD GUIDE ARM BASE	糸立て糸案内腕台	(1)
25		SM-4041001-SC	SCREW M4X0.7 L=10	なべ小ねじ M4 X 0.7 L=10	(2)
26		NM-6040002-SE	NUT M4X0.7	六角ナット M4 X 0.7 2種	(2)
27		SM-4041201-SC	SCREW M4 L=12	なべ小ねじ M4 L=12	(1)
28		SM-4042001-SC	SCREW M4 X 20	なべ小ねじ M4 X 0.7 L=20	(1)
29		NM-6040002-SE	NUT M4X0.7	六角ナット M4 X 0.7 2種	(2)

20. OPERATION PANEL COMPONENTS

操作パネル関係

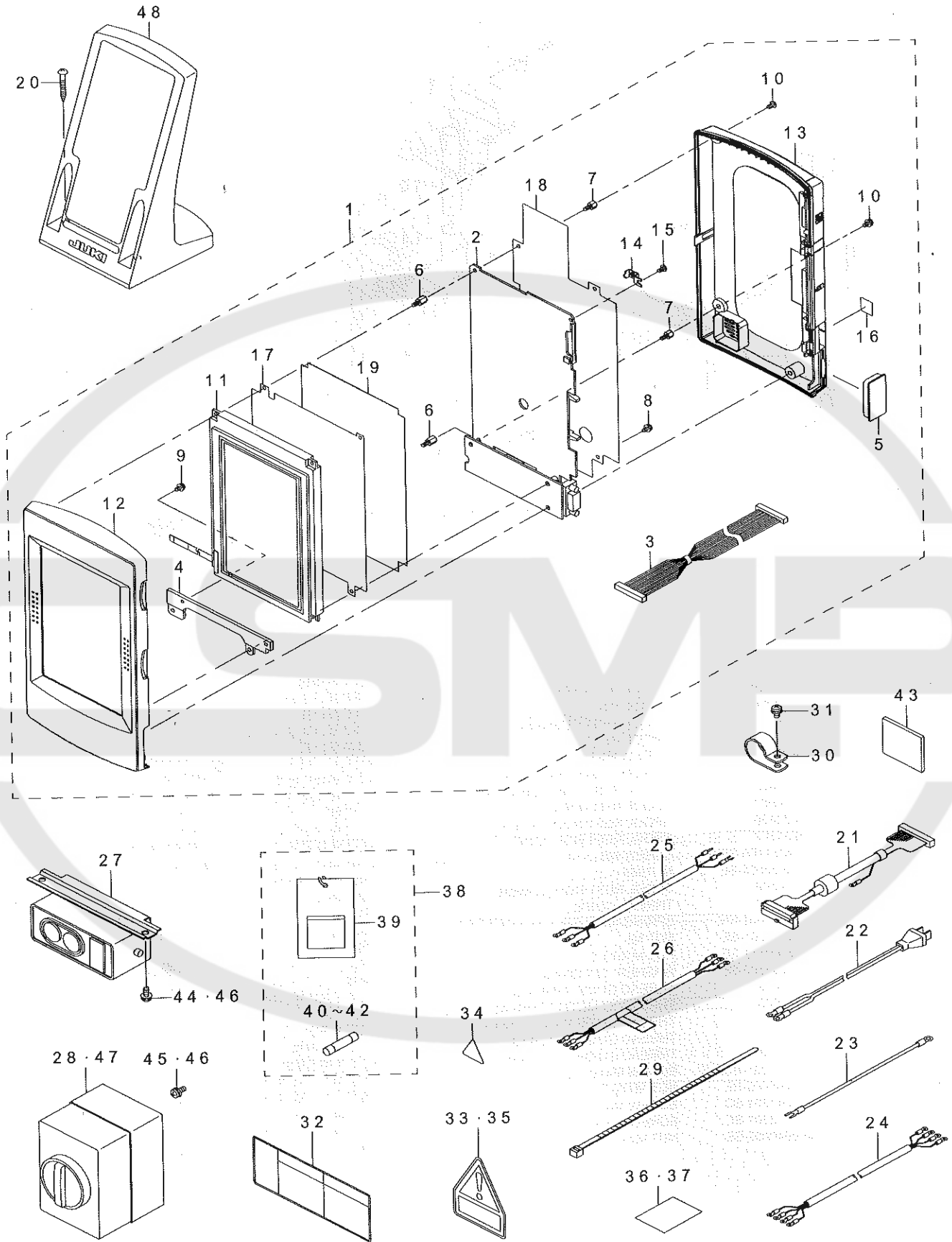

REF.NO	NOTE	PART NO	DESCRIPTION	品 名	Qty
1		400-77848	IP-410H PANEL ASSY	IP-410H パネル組	1
2		400-76012	PANEL PCB B A ASSY	パネル基板 B A 組	(1)
3		400-00146	LCD CABLE ASSY	LCD ケーブル組	(1)
4		400-30926	LCD HOLDER BOARD	LCD 支え板	(1)
5		400-05848	D-SUB 9P COVER	D-SUB 9P カバー	(1)
6		HX-0035400-0N	SPACER	スペーサ	(5)
7		HX-0035400-0S	SPACER	スペーサ	(2)
8		SL-4030691-SC	SCREW M3X6	なべ小ねじセムス M3 X 0.5 L=6	(1)
9		SL-4030691-SC	SCREW M3X6	なべ小ねじセムス M3 X 0.5 L=6	(2)
10		SM-4030501-SF	SCREW M3 L=5	なべ小ねじ M3 L=5	(4)
11		400-51330	IP-410_LCD_ASSY	IP-410 LCD 組	(1)
12		400-46076	IP-410_FRONT_CASE_ASSY	IP-410 フロントケース組	(1)
13		400-76009	REAR CASE B ASSY	リアケース B 組	(1)
14		400-44971	REAR_CASE_PLATE	リアケース取付板	(1)
15		SM-4030501-SF	SCREW M3 L=5	なべ小ねじ M3 L=5	(1)
16		CM-6001001-01	WEEE MARK LABEL S	WEEE マーク ラベル S	(1)
17		400-76031	EMC SHIELDING SHEET C	EMC 保護シート C	(1)
18		400-76032	EMC SHIELDING SHEET D	EMC 保護シート D	(1)
19		400-00140	ISOLATION_SHEET	ISOLATION_シート	(1)
20		SK-3413201-SE	WOOD SCREW D=4.1 L=32	丸木ねじ D=4.1 L=32	2
21		400-73679	PANEL CABLE ASSY L	パネルケーブル組 L	1
22	#01	M9035-580-0A0	POWER SOURCE CORD ASM.	100V 用電源組	1
23	#01	M9034-580-0A0	GROUND CORD ASM.	100V 用アースコード組	1
24	#02	400-79638	POWER CABLE ASM.	電源ケーブル組	1
25	#03	400-79639	JE POWER CABLE ASM	JE 電源ケーブル組	1
26	#04	400-79640	SINGLE PHASE POWER CORD ASSY	単相用電源コード組	1
27	#05	HA-0042500-00	SWITCH	スイッチ	1
28	#10	HA-0058200-00	SWITCH	スイッチ	1
29		HX-0006500-0A	CABLE CLIP	束線バンド	2
30		HX-0015000-0J	CLIP	ケーブル クリップ	2
31		SL-4040691-SC	SCREW M4 L=6	座金付きなべ小ねじ M4 L=6	2
32	#06	CM-3001004-01	LABEL 3 (LARGE)	電撃危険ラベル3 (大)	1
33	#02	CM-3004007-01	VOLTAGE CAUTION LABEL	電圧注意シール	1
34	#07	CM-3001000-03	VOLTAGE WARNING LABEL(25)	危険電圧警告ラベル(25)	1
35	#07	CM-3004006-01	VOLTAGE CAUTION LABEL	電圧注意シール	1
36	#01	BME-01100000	VOLTAGE INDICATION SEAL	電圧表示シール 単相100V	1
37	#02	BME-03200000	VOLTAGE INDICATION SEAL	電圧表示シール 三相200V	1
38		400-74051	OPTION A ASSY	オプション A 組	1
39		M3004-511-00A	VOLTAGE INDICATION CARD,A	電圧表示蓋 A	(1)
40		HF-0013031-5S	FUSE 3.15A 250V REF. NO.112	ヒューズ (3.15A)	(1)
41		HF-0030002-00	FUSE 2A (220/240V)	ヒューズ	(1)
42		HF-0013050-P0	FUSE 5A	ヒューズ 5A	(1)
43		400-50647	COMPACTFLASH(TM) SET AMS221E	AMS 221 E コンパクトフラッシュ(TM) セット	1
44	* #08	SL-4040891-SC	SCREW M4 L=8	座金付きなべ小ねじ M4 L=8	2
45	#03	SL-4041091-SC	SCREW M4 L=10	なべ小ねじセムス M4 X 0.7 L=10	2
46	#09	SK-3512001-SE	WOOD SCREW D=5.1 L=20	丸木ねじ D=5.1 L=20	2
47	#09	M8512-581-0A0	POWER SWITCH ASM.	電源スイッチ組	1
48		400-35024	OPERATION_BOX_FIXED_PLATE(B) ASM.	操作箱取付板 (B) 組	1
	NOTE(注記)		#01...FOR USE IN JAPAN(1-PHASE 100V)	日本用 (単相100V)	
			#02...FOR USE IN JAPAN(3-PHASE 200V), JUS(3-PHASE 220V)	日本用 (三相200V), JUS (三相220V)	
			#03...FOR CE(1-PHASE 230V)	CE 用 (単相230V)	
			#04...GENERAL EXPORT (1-PHASE 220V/230V/240V)	一般輸出 (単相220V/230V/240V)	
			#05...EXCEPT CE(1-PHASE 230V)	CE を除く (単相230V)	
			#06...FOR USE IN JAPAN (1-PHASE 100V,3-PHASE 200V), JUS(3-PHASE 220V)	日本用 (単相100V, 三相200V), JUS (三相220V)	
			#07...FOR CE(1-PHASE 230V), GENERAL EXPORT (1-PHASE 220V/230V/240V)	CE (単相230V), 一般輸出 (単相220V/230V/240V) 用	
			#08...FOR 4530	4530用	
			#09...FOR 6030	6030用	
			#10...FOR CE(1-PHASE 230V),4530	CE (単相230V), 4530用	

21. CONTROL BOX COMPONENTS

電装ボックス関係

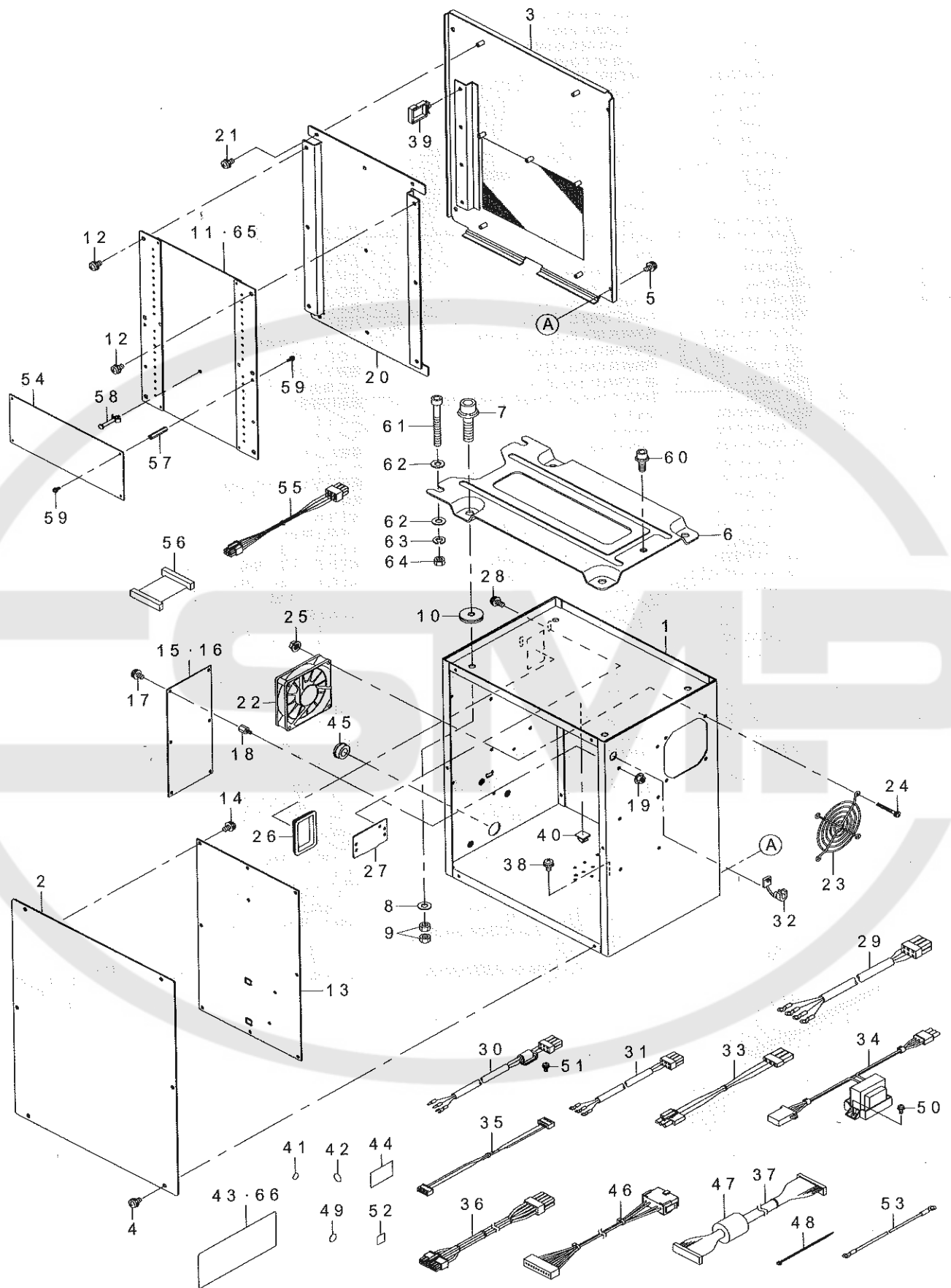

REF.NO	NOTE	PART NO	DESCRIPTION	品名	Qty
1		400-55355	CONTROL BOX	電装ボックス	1
2		400-55356	CONTROL BOX FRONT COVER	電装ボックス前蓋	1
3		400-55357	CONTROL BOX REAR COVER	電装ボックス後ろ蓋	1
4		SL-4040891-SC	SCREW M4 L=8	座金付きなべ小ねじ M4 L=8	6
5		SL-4040891-SC	SCREW M4 L=8	座金付きなべ小ねじ M4 L=8	4
6		M3801-476-000	CONTROL BOX FITTING PLATE	電装ボックス取付板	1
7		SL-6083092-TN	SCREW	座金付き六角穴ボルト	4
8		WP-0841601-SC	WASHER 8.4X17.4X1.6	平座金みがき丸 M8	4
9		NM-6080001-SC	NUT M8X1.25	六角ナット M8 1種	8
10		M4206-461-000	WASHER	ゴム付き座金	4
11	#06	400-73650	MAIN PCB ASSY	MAIN 基板組	1
12		SL-4040891-SC	SCREW M4 L=8	座金付きなべ小ねじ M4 L=8	6
13		400-00029	SDC PCB A ASS'Y	SDC 基板 A 組	1
14		SL-4040881-SC	SCREW M4 L=8	座金付きなべ小ねじ M4 L=8	10
15	#01	400-00056	FLT-T PCB A ASS'Y	FLT-T 基板 A 組	1
16	#02	400-00046	FLT-S PCB A ASS'Y	FLT-S 基板 A 組	1
17		SL-4040881-SC	SCREW M4 L=8	座金付きなべ小ねじ M4 L=8	6
18		HX-0033900-00	STUD	基板パーツ	6
19		NM-3040520-SC	NUT M4	フランジ付きナット M4	6
20		400-05706	MAIN PCB HOLDER PLATE	MAIN 基板止め板	1
21		SL-4040881-SC	SCREW M4 L=8	座金付きなべ小ねじ M4 L=8	5
22		400-05401	FAN MOTOR ASS'Y	ファンモータ組	1
23		KM-0000004-80	FAN MOTOR	フィンガーガード	1
24		SL-4043591-SC	SCREW	座金付きなべ小ねじ	4
25		NM-3040520-SC	NUT M4	フランジ付きナット M4	4
26		HX-0040700-00	BUSH	ブッシュ	1
27		178-45009	CORD FITTING PLATE	コード止め板	1
28		SL-4041091-SC	SCREW M4 L=10	なべ小ねじセムス M4 X 0.7 L=10	2
29	#01	400-73683	POWER CORD 3P ASSY	電装電源コード3P組	1
30	#03	400-05392	POWER CORD 1P ASS'Y	電装電源コード1P組	1
31	#04	400-73684	POWER CORD 1P 220V ASSY	電装電源コード1P 220V組	1
32		HX-0041000-0A	STRAIN RELIEF BUSHING	ストレーンリリーフブッシング	1
33	#05	400-05393	FLT-SDC CORD P ASSY	FLT-SDC コードP組	1
34	#03	400-12038	REACTOR CORD ASSY	リアクタコード組	1
35		400-05394	FLT-SDC CORD S ASSY	FLT-SDC コードS組	1
36		400-05726	SDC-MAIN CORD P ASSY	SDC-MAIN コードP組	1
37		400-05727	SDC-MAIN CORD S ASSY	SDC-MAIN コードS組	1
38		SL-4040891-SC	SCREW M4 L=8	座金付きなべ小ねじ M4 L=8	4
39		HX-0051100-00	WIRE SADDLE	ワイヤサドル	3
40		E9607-603-000	STICKER (SMALL)	ステッカー (小)	1
41		E9567-319-000	EARTH MARK	アースマーク	1
42		400-03458	MASK SEAL	マスクシール	16
43	#05	400-51640	UNIVERSAL_RATING_LABEL	ユニバーサル定格銘板	1
44		400-18948	MASK SEAL R	マスクシールR	1
45		HX-0032600-0K	GROMMET	束線パーツ	1
46		400-73659	SW RELAY CORD ASM.	SW 中継コード組	1
47		HN-0014900-00	CLAMP FILTER(L)	クランプフィルタ	1
48		EA-9500B01-00	CABLE BAND	束線バンド	1
49	#03	CM-2001000-01	PE MARK LABEL	PE マークシール	1
50	#03	SL-4041091-SC	SCREW M4 L=10	なべ小ねじセムス M4 X 0.7 L=10	2
51	#03	SL-4041081-SC	SCREW M4 L=10	なべ小ねじセムス M4 L=10	1
52	#03	CM-6001001-01	WEEE MARK LABEL S	WEEE マーク ラベル S	1
53		M9029-580-0A0	FDD EARTH CORD ASM.	FDD アース線組	1
54		400-73651	SUB PCB ASSY	SUB 基板組	1
55		400-62367	SUB-MAIN CORD P ASSY	SUB-MAIN コードP組	1
56		400-62368	SUB-MAIN CORD S ASSY	SUB-MAIN コードS組	1
57		HX-0041800-0E	SPACER	スペーサ	4
58		HX-0014700-0J	SPACER	基板スペーサ	1
59		SL-4030881-SC	SCREW M3X8	なべ小ねじセムス M3 X 0.5 L=8	8
60		SL-6082092-TN	BOLT	座金付六角穴ボルト	1
61	*	SM-6087002-TN	SCREW M8 L=70	六角穴ボルト M8 L=70	2
62		WP-0841601-SC	WASHER 8.4X17.4X1.6	平座金みがき丸 M8	4
63		WS-0820002-KN	SPRING WASHER M8	ばね座金 M8	2
64		NM-6080001-SC	NUT M8X1.25	六角ナット M8 1種	2
65	#07	400-77782	MAIN PCB ASSY	MAIN 基板組	1
66	#03	400-57278	UNIVERSAL_RATING_LABEL	定格銘板 CE	1

NOTE(注記)

#01...FOR USE IN JAPAN
(1-PHASE 100V, 1-PHASE 200V), JUS(3-PHASE 200V) 日本 (単相100V, 単相200V), JUS (三相200V) 用

#02...FOR CE, GENERAL EXPORT CE, 一般輸出用

#03...FOR CE CE 用

#04...GENERAL EXPORT 一般輸出

#05...FOR USE IN JAPAN
(1-PHASE 100V, 1-PHASE 200V), JUS(3-PHASE 200V), GENERAL EXPORT 日本 (単相100V, 単相200V), JUS (三相200V), 一般輸出用

#06...FOR 4530 4530 用

#07...FOR 6030 6030 用

22. WIRING DIAGRAM

電装配線図

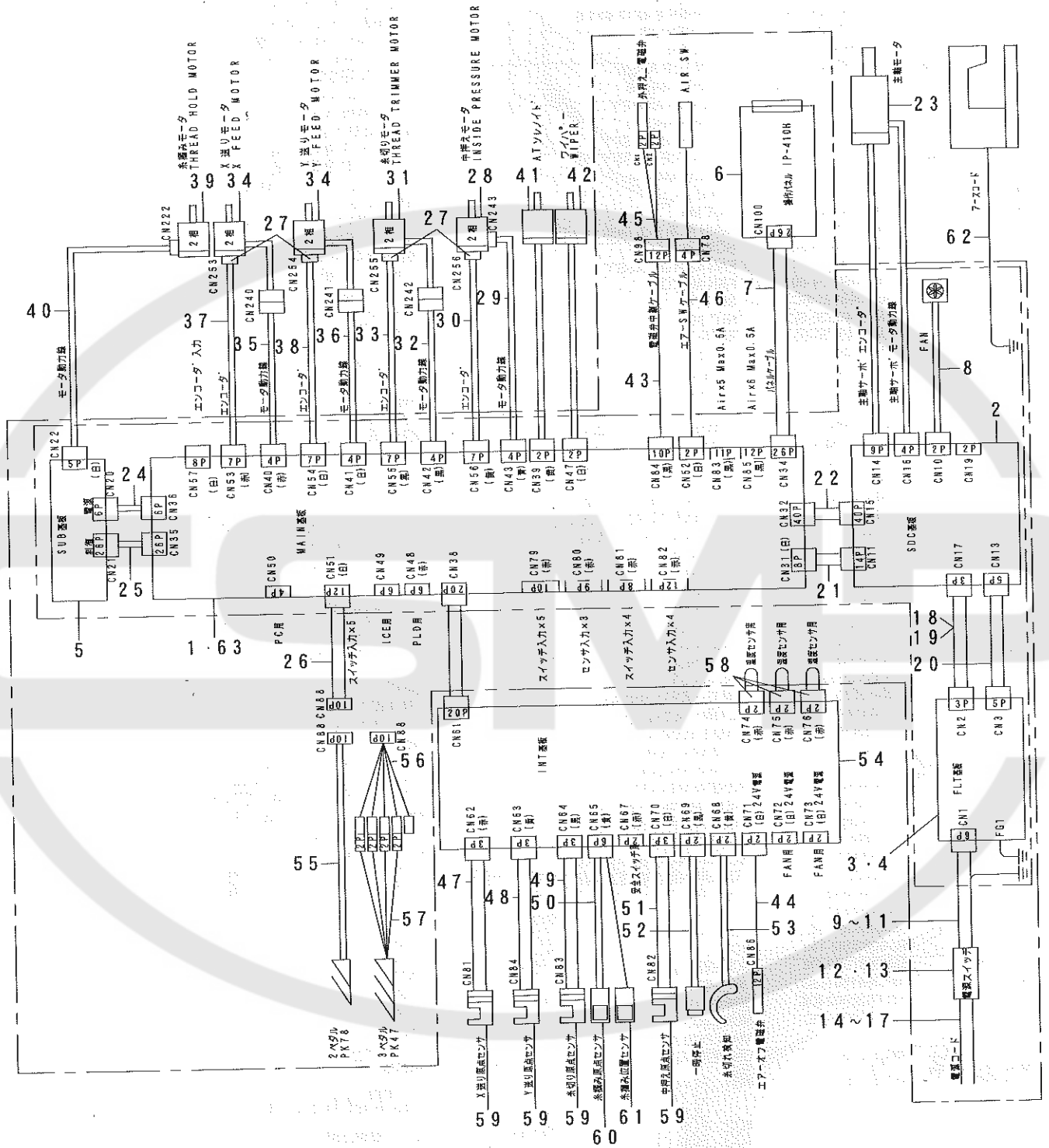

REF.NO	NOTE	PART NO	DESCRIPTION	品名	Qty
1	#09	400-73650	MAIN PCB ASSY	MAIN 基板組	1
2		400-00029	SDC PCB A ASS'Y	SDC 基板 A 組	1
3	#01	400-00056	FLT-T PCB A ASS'Y	FLT-T 基板 A 組	1
4	#02	400-00046	FLT-S PCB A ASS'Y	FLT-S 基板 A 組	1
5		400-73651	SUB PCB ASSY	SUB 基板組	1
6		400-77848	IP-410H PANEL ASSY	IP-410H パネル組	1
7		400-73679	PANEL CABLE ASSY L	パネルケーブル組 L	1
8		400-05401	FAN MOTOR ASS'Y	ファンモータ組	1
9	#01	400-73683	POWER CORD 3P ASSY	電装電源コード3P組	1
10	#03	400-05392	POWER CORD 1P ASS'Y	電装電源コード1P組	1
11	#04	400-73684	POWER CORD 1P 220V ASSY	電装電源コード1P220V組	1
12	#05	HA-0042500-00	SWITCH	スイッチ	1
13	#03	HA-0058200-00	SWITCH	スイッチ	1
14	#07	M9035-580-0A0	POWER SOURCE CORD ASM.	100V ヨウデンゲンコード組	1
15	#08	M9017-580-0A0	POWER CABLE ASM.	電源ケーブル組	1
16	#03	400-05390	JE POWER CABLE ASM	JE 電源ケーブル組	1
17	#04	400-23371	SINGLE PHASE POWER CORD ASSY	単相用電源コード組	1
18	#05	400-05393	FLT-SDC CORD P ASS'Y	FLT-SDC コードP組	1
19	#03	400-12038	REACTOR CORD ASSY	リアクタコード組	1
20		400-05394	FLT-SDC CORD S ASS'Y	FLT-SDC コードS組	1
21		400-05726	SDC-MAIN CORD P ASSY	SDC-MAIN コードP組	1
22		400-05727	SDC-MAIN CORD S ASSY	SDC-MAIN コードS組	1
23		400-52937	550W_SERVO MOTOR	550W サーボモータ	1
24		400-62367	SUB-MAIN CORD P ASSY	SUB-MAIN コードP組	1
25		400-62368	SUB-MAIN CORD S ASSY	SUB-MAIN コードS組	1
26		400-73659	SW RELAY CORD ASM	SW 中継コード組	1
27		HD-0027800-00	SENSOR	センサー	4
28		400-71942	STEPPING MOTOR	ステッピングモータ	1
29		400-73623	IP MOTOR CABLE ASM	中押えモータケーブル組	1
30		400-73640	IP ENCODER CABLE ASM	中押えエンコーダケーブル組	1
31		400-71944	STEPPING MOTOR	ステッピングモータ	1
32		400-73622	TT MOTOR CABLE ASM	糸切りモータケーブル組	1
33		400-73639	TT ENCODER CABLE ASM	糸切りエンコーダケーブル組	1
34		400-71945	STEPPING MOTOR	ステッピングモータ	2
35		400-73620	X MOTOR CABLE ASM	X モータケーブル組	1
36		400-73621	Y MOTOR CABLE ASM	Y モータケーブル組	1
37		400-73632	X ENCODER CABLE ASM	X エンコーダケーブル組	1
38		400-73638	Y ENCODER CABLE ASM	Y エンコーダケーブル組	1
39		400-75079	STEPPING MOTOR	ステッピングモータ	1
40		400-73626	TH MOTOR CABLE ASM	糸掴みモータケーブル組	1
41		400-73660	AT SOLENOID	AT ソレノイド	1
42		400-72151	WIPER ASM	ワイパー組	1
43		400-73681	AIR RELAY CABLE ASM	エア-中継ケーブル組	1
44		400-74987	VALVE COAD ASM	電磁弁コード組	1
45		400-48529	VALVE RERAY COAD ASM	電磁弁中継コード組	1
46		400-75391	AIR SW CABLE ASM	エア-スイッチケーブル組	1
47		400-73671	X SENSOR CABLE ASM	X センサケーブル組	1
48		400-73672	Y SENSOR CABLE ASM	Y センサケーブル組	1
49		400-40238	PF_SENSOR_CABLE_ASM	糸切り原点センサケーブル組	1
50		400-73674	TH_SENSOR_ASM	糸掴みセンサ組	1
51		400-73675	IP_SENSOR_CABLE_ASM	中押え可変センサケーブル組	1
52		400-73676	STOP SW ASM	一時停止スイッチ組	1
53		400-73678	THB_SENSOR_CABLE_ASM	糸切れセンサケーブル組	1
54		400-40230	INT PCB ASM	INT 基板組	1
55		400-33831	PK78 PEDAL SWITCH ASM	PK 78 ペダルスイッチ組	1
56	#06	400-33875	PK47 RELAY CABLE ASM	PK 47 中継ケーブル組	1
57	#06	GPK-470010AB	3-PEDAL ASM.	3連ペダル組	1
58		400-40237	SHORT CONNECTOR	ショート コネクタ	3
59		HD-0005700-0A	PHOTO SENSOR	フォトセンサ	3
60		HD-0020400-0A	SENSOR	センサ	1
61		HD-0020400-0B	SENSOR	センサ	1
62		141-15554	HEAD GROUND CABLE A ASM.	頭部アースケーブル A 組	1
63	#10	400-77782	MAIN PCB ASSY	MAIN 基板組	1
		NOTE(注記)	#01...FOR 1-PHASE/3-PHASE	単相/三相用	
			#02...FOR CE, GENERAL EXPORT	CE, 一般輸出用	
			#03...FOR CE	CE 用	
			#04...GENERAL EXPORT	一般輸出	
			#05...FOR 1-PHASE/3-PHASE, GENERAL EXPORT	単相/三相, 一般輸出用	
			#06...OPTIONAL PARTS	オプション部品	
			#07...FOR USE IN JAPAN (1-PHASE 100V)	日本 (単相100V) 用	
			#08...FOR 3-PHASE	三相用	
			#09...FOR 4530	4530 用	
			#10...FOR 6030	6030 用	

23. TABLE COMPONENTS

脚卓関係

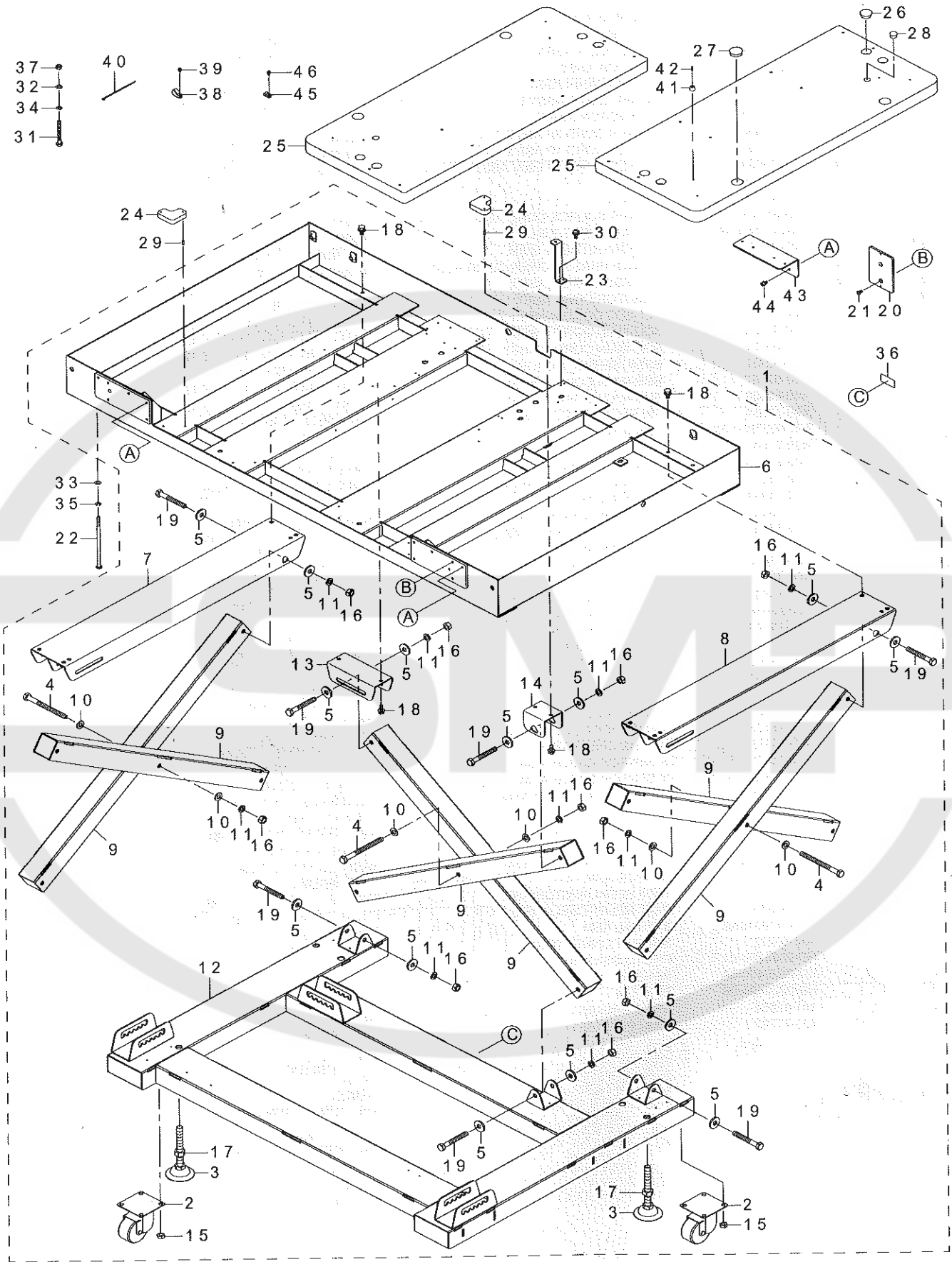

REF.NO	NOTE	PART NO	DESCRIPTION	品名	Qty
1		400-72145	STAND ASM	脚組	1
2		400-72077	CASTER	キャスター	(4)
3		400-72087	ADJUSTER	アジャスター	(4)
4		400-72206	BOLT	六角ボルト	(3)
5		400-72223	WASHER LARGE	脚卓ボルト座金	(24)
6		400-73222	UPPER_STAND	上脚	(1)
7		400-73224	TOP_BASE_L	上脚土台左	(1)
8		400-73225	TOP_BASE_R	上脚土台右	(1)
9		400-73226	CROSS_LEG	支柱	(6)
10		WP-1302501-SC	WASHER 13X24X2.5	平座金 13 X 24 X 2.5	(6)
11		WS-1220002-KN	SPRING WASHER	ばね座金	(15)
12		400-73227	BASE	土台	(1)
13		400-73230	BRACKET_BT	上脚後ろ調節支え	(1)
14		400-73231	BRACKET_B	上脚後ろ支え	(1)
15		NM-6100001-SE	NUT FOR SPRING ADJUSTING BOLT	六角ナット M10 1種	(16)
16		NM-6120001-SE	NUT M12	六角ナット	(15)
17		NM-6160001-SC	NUT	フレーム調整ボルトナット	(4)
18		SL-9082093-SE	SCREW	座金付き六角穴ボルト	(12)
19		SM-9129013-SB	SCREW M12 L=90	六角ボルト M12 L=90	(12)
20	#02	400-73216	SW_BASE_JE	電源 SW 土台 JE	1
21	#02	SM-1061201-SN	SCREW M6 L=12	皿小ねじ M6 L=12	2
22		B8117-223-C00	BOLT	テーブル固定ボルト	4
23		B8118-223-C00	COVER INSTALLING STAY	カバー取付ステー	4
24		B8171-220-000	RUBBER ABSORBER	防振ゴム B	4
25		400-72146	TABLE	テーブル	2
26		HX-0032600-0B	BUSH	ブッシュ	5
27		HX-0032600-0M	DOME PLUG	ドーム プラグ	3
28		HX-0032600-0G	PLUG	束線パーツ	3
29		PS-0400141-KH	SPRING PIN 4X14	スプリングピン 4 X 14	8
30		SL-4041091-SC	SCREW M4 L=10	なべ小ねじセムス M4 X 0.7 L=10	8
31		SM-9087533-SC	SCREW M8 L=75	六角ボルト M8 L=75	2
32		WP-0841601-SC	WASHER 8.4X17.4X1.6	平座金みがき丸 M8	2
33		WP-0841601-SC	WASHER 8.4X17.4X1.6	平座金みがき丸 M8	4
34		WS-0820002-KN	SPRING WASHER M8	ばね座金 M8	2
35		WS-0820002-KN	SPRING WASHER M8	ばね座金 M8	4
36		168-70206	GRAVITY SEAL	荷重中心シール	2
37		NM-6080001-SC	NUT M8X1.25	六角ナット M8 1種	2
38		HX-0015000-0H	CABLE CLIP	ケーブルクリップ	3
39	*	SL-4040891-SC	SCREW M4 L=8	座金付きなべ小ねじ M4 L=8	3
40		EA-9500B01-00	CABLE BAND	束線バンド	2
41		400-72231	STOPPER RUBBER	操作パネルストッパー	2
42		SK-3271301-SE	WOOD SCREW D=2.7 L=13	丸木ねじ D=2.7 L=13	2
43	#01	400-73215	SW_BASE	電源 SW 取付板	1
44	#01	SL-6061292-TN	SCREW	座金付き六角穴ボルト	2
45	*	HX-0015000-0B	CABLE CLIP	ケーブルクリップ	1
46	*	SL-4041091-SC	SCREW M4 L=10	なべ小ねじセムス M4 X 0.7 L=10	1
		NOTE(注記)	#01...FOR ST(4530) #02...FOR JE(4530)	ST用(4530) JE用(4530)	

24. PEDAL COMPONENTS

ペダル関係

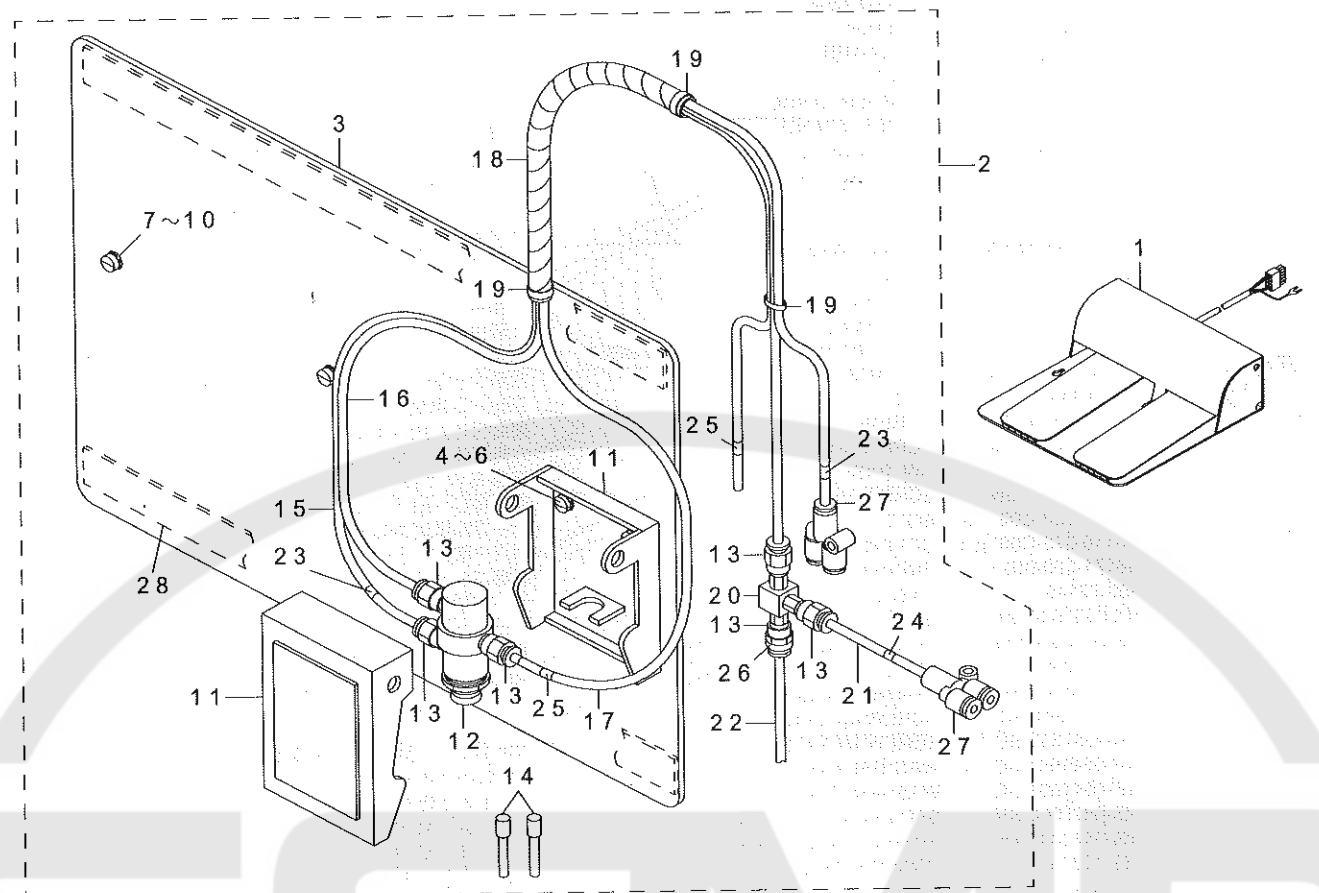

REF.NO	NOTE	PART NO	DESCRIPTION	品名	Qty
1		400-33831	PK78 PEDAL SWITCH ASM.	PK 78 ペダルスイッチ組	1
2		400-42352	MECHANICAL VALVE UNIT	メカニカルバルブユニット	1
3		D8001-D15-A0Y	PEDAL BASE	ペダルベース	(1)
4		WP-0450801-SD	WASHER 4.5X10X0.8	平座金 4.5 X 10 X 0.8	(2)
5		WS-0451040-KP	SPRING WASHER 4.5X8.5X1	ばね座金 4.5 X 8.5 X 1	(2)
6		SS-7111120-TP	SCREW	丸平ねじ	(2)
7		SS-6111210-SP	SCREW 11/64-40 L=12	平ねじ 11/64-40 L=12	(2)
8		WP-0450801-SD	WASHER 4.5X10X0.8	平座金 4.5 X 10 X 0.8	(2)
9		WS-0451040-KP	SPRING WASHER 4.5X8.5X1	ばね座金 4.5 X 8.5 X 1	(2)
10		WP-0553216-SD	WASHER	平座金	(2)
11		PX-0200020-00	ACTUATOR	アクチュエーター	(1)
12		PV-0105020-00	AIR VALVE	エアバルブ	(1)
13		PJ-3010405-01	HALF UNION M5 D=4	ワンタッチ継ぎ手 M5 D=4	(6)
14		PX-5000140-00	PLUG	止栓	(2)
15		BT-0400251-EB	URETHANE HOSE, BLACK	ウレタンホース 黒	(1.9)
16		BT-0400251-EB	URETHANE HOSE, BLACK	ウレタンホース 黒	(1.8)
17		BT-0400251-EB	URETHANE HOSE, BLACK	ウレタンホース 黒	(1.9)
18		HX-0031400-0A	SPIRAL TUBE	スパイラル チューブ	(0.6)
19		EA-9500B01-00	CABLE BAND	束線バンド	(3)
20		GEP-01013000	VALVE	エキゾストバルブ	(1)
21		BT-0400251-EB	URETHANE HOSE, BLACK	ウレタンホース 黒	(0.1)
22		BT-0400251-EB	URETHANE HOSE, BLACK	ウレタンホース 黒	(0.1)
23		180-35204	WIRE MARK (3)	ワイヤーマーク (3)	(2)
24		180-35303	WIRE MARK (4)	ワイヤーマーク (4)	(1)
25		180-35600	WIRE MARK (7)	ワイヤーマーク (7)	(2)
26		180-35709	WIRE MARK (8)	ワイヤーマーク (8)	(1)
27		PJ-3080400-02	QUICK COUPLING	ワンタッチ継ぎ手	(2)
28		D8002-D15-A0Y	PEDAL CUSHION	ペダルクッション	(2)

25. ACCESSORIE PART COMPONENTS

付属品関係

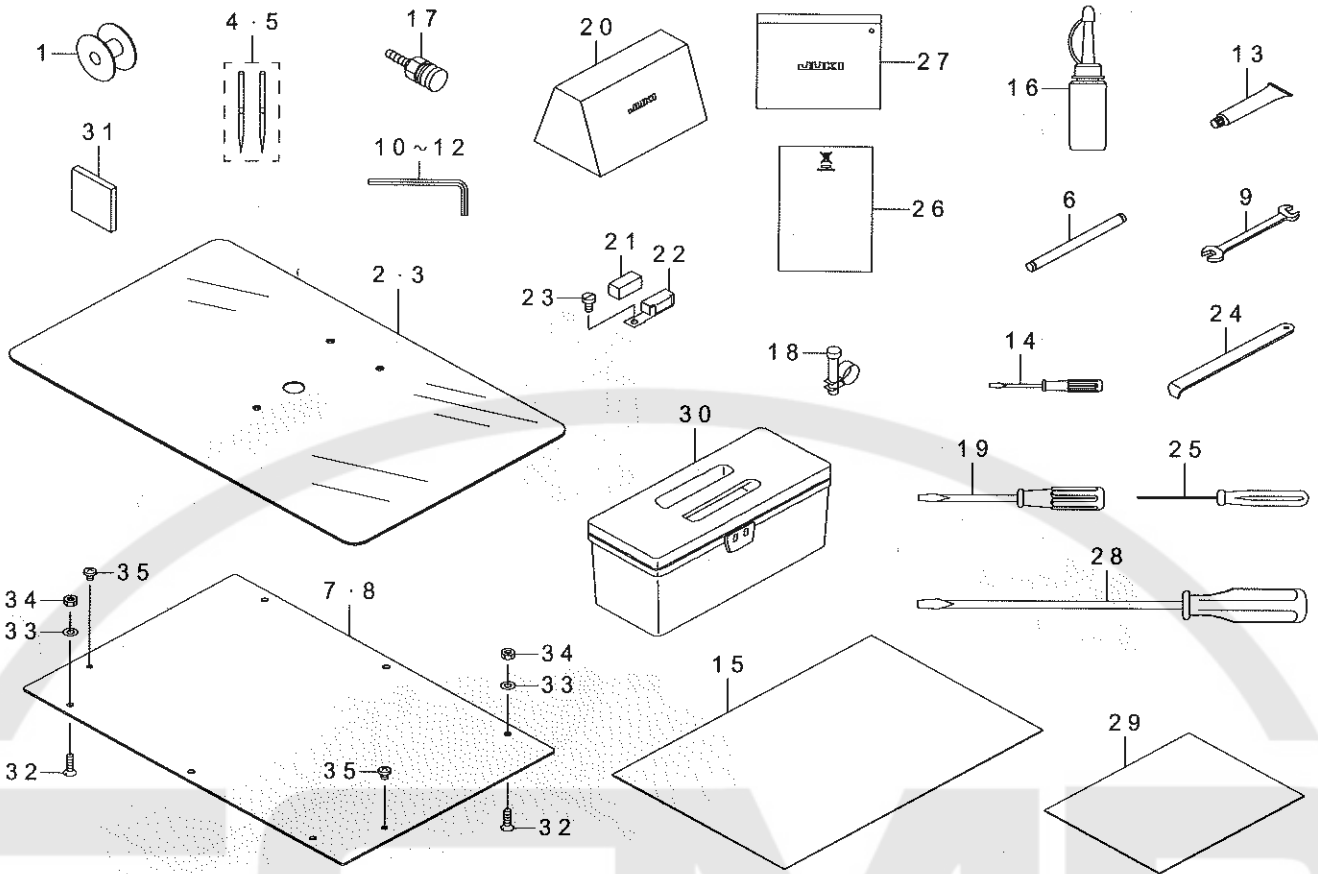

REF.NO	NOTE	PART NO	DESCRIPTION	品名	Qty
1	☆	B1806-210-D00	BOBBIN	ボビン	1
2	#03	400-72082	COVER SHEET(4530)	針板補助カバーシート (4530)	1
3	#04	400-72083	COVER SHEET(6030)	針板補助カバーシート (6030)	1
4	☆	MDP-170B1802	NEEDLE DPZ17#18-2	DPX 17#18-2	1
5	☆	MC-3720011-02	NEEDLE SY3355 #110-2	SY 3355 #110-2	1
6		137-04705	BELT SIDE COVER SHAFT	側面ベルトカバー軸	1
7	#04	400-72148	PLASTIC BLANK PLATE 6030	プラスチックプランク 6030	1
8	#03	400-72147	PLASTIC BLANK PLATE 4530	プラスチックプランク 4530	1
9		B9113-012-000	WRENCH (9X10)	両口スパナ (小)	1
10		B9140-372-000	HEXAGONAL WRENCH, SMALL	六角棒スパナ (小)	1
11		B9141-372-000	HEXAGONAL WRENCH, LARGE	六角棒スパナ (大)	1
12		GCT-02906000	HEXAGONAL SPANNER	六角棒スパナ	1
13		400-06323	JUKI GREASE A TUBE	JUKI グリース A チューブ	1
14		229-33204	SCREW DRIVER, SMALL	ドライバー (小)	1
15		B2564-223-C00	SPONGE	布押え外枠スポンジ	1
16		B9121-220-0A0	OILER (CONTAINING NO.2 OIL)	油注し NO. 2	1
17		PJ-3096200-01	SOCKET	ハイカプランケット	1
18		PB-0000100-00	HOSE BAND	ホースバンド	1
19		229-33105	SCREW DRIVER, MIDDLE	ドライバー (中)	1
20		400-72154	COVER	頭部カバー	1
21		B1131-528-000	FELT	糸案内系押え	1
22		101-02200	THREAD GUIDE F	糸案内 F	1
23		SM-6040860-TP	SCREW M4 L=8	ねじ M4 L=8	1
24		B9101-490-000	DRIVER	ドライバー	1
25		400-32763	HEXAGONAL DRIVER(1.5)	六角ドライバー (1.5)	1
26	#02	CM-6001002-01	WEEE INFORMATION SHEET	WEEE インフォメーション シート	1
27		229-32800	ACCESSORIE BAG	付属品バッグ	1
28		229-33006	SCREW DRIVER, LARGE	ドライバー (大)	1
29		B2591-220-000	RUBBER SHEET	布押え用ゴムシート	1
30		B8601-WP1-0A0	TOOL BOX ASM.	工具箱組	1
31		400-50647	COMPACTFLASH(TM) SET AMS-221E	コンパクトフラッシュ (TM) セット	1
32	*	SM-1041401-SN	SCREW M4X0.7 L=14	皿小ねじ M4 X 0.7 L=14	6
33		WP-0430801-SC	WASHER 4.3X9X0.8	平座金 4.3 X 9 X 0.8	6
34		NM-6040001-SC	NUT M4	六角ナット M4	6
35		SM-4040501-SN	SCREW M4X0.7 L=5	なべ小ねじ M4 X 0.7 L=5	2

NOTE (注記)

#01...FOR ST
 #02...FOR JE
 #03...FOR AMS-224E-4530
 #04...FOR AMS-224E-6030

ST 用
 JE 用
 AMS-224E-4530 用
 AMS-224E-6030 用

26. TYPE G EXCLUSIVE PARTS

G仕様専用部品

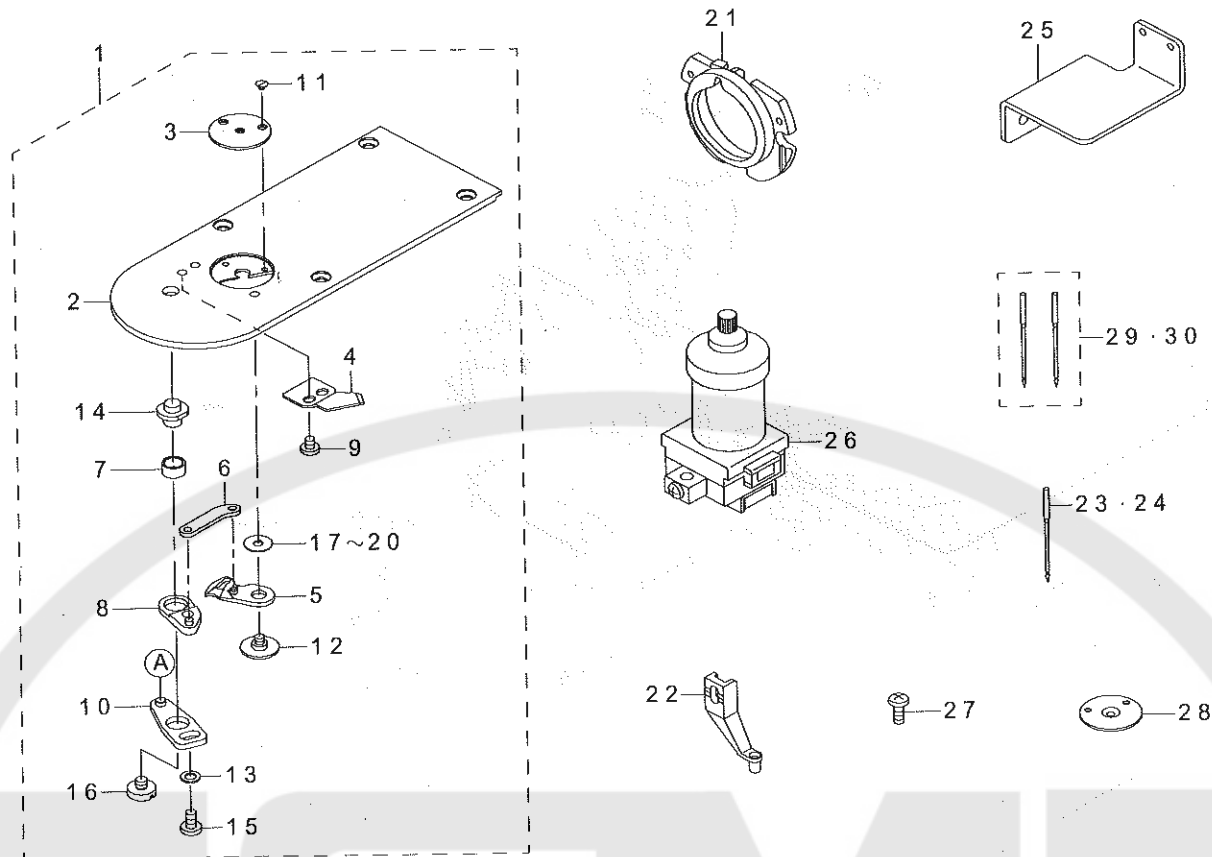

REF.NO	NOTE	PART NO	DESCRIPTION	品名	Qty
1		400-53776	NEEDLE PLATE ASM.	針板組	1
2		400-30934	NEEDLE PLATE	針板	(1)
3		B2426-210-00F	NEEDLE HOLE GUIDE D=3.0	針穴ガイド 3	(1)
4		B2424-210-A00	FIX KNIFE	固定メス	(1)
5		B2421-210-AA0	MOVING KNIFE COMPL.	動メス結合	(1)
6		B2416-280-000	MOVING KNIFE LINK	動メスリンク	(1)
7		B2416-280-000	THREAD CUTTING LEVER RING	糸切りレバーリング	(1)
8		B2415-280-0A0	THREAD CUTTER LEVER ASM., SMALL	糸切りレバー (小) 組	(1)
9		SS-7090410-SP	SCREW 9/64-40 L=3.5	丸平ねじ 9/64-40 L=3.5	(1)
10		B2414-280-0A0	THREAD CUTTER LEVER ASM., LARGE	糸切りレバー (大) 組	(1)
11		SS-1060210-TP	SCREW 3/32-56 L=2.2	皿ねじ 3/32-56 L=2.2	(1)
12		B2417-210-000	MOVING KNIFE HINGE SCREW	動メス段ねじ	(1)
13		WP-0450846-SP	WASHER	平座金	(1)
14		B2417-280-000	THREAD CUTTER LEVER SHAFT	糸切りレバー軸	(1)
15		SS-7110740-TP	SCREW 11/64-40 L=7	丸平ねじ 11/64-40 L=7	(1)
16		SS-6110430-TP	SCREW 11/64-40 L=4.0	平ねじ 11/64-40 L=4	(1)
17	#01	B2423-280-00A	MOVING KNIFE WASHER A	動メス座金 A	(1)
18	#01	B2423-280-00B	MOVING KNIFE WASHER B	動メス座金 B	(1)
19	#01	B2423-280-00C	MOVING KNIFE WASHER C	動メス座金 C	(1)
20	#01	B2423-280-00D	MOVING KNIFE WASHER D	動メス座金 D	(1)
21		141-03659	SHUTTLE RACE RING ASM., C	中签押え C 結合	1
22		B1601-210-D08-A	INTERMEDIATE PRESSER B	中押え B	1
23	#02	MDP-170B2300	NEEDLE DPX17 #23	針 DPX17 #23	1
24	#03	MC-3720016-00	NEEDLE SY3355 160	針 SY3355 160	1
25	#04	B2535-210-000	TANK BASE	エスレンタンク台	1
26	#04	B3532-223-C00	SILICON TANK	エスレンタンク	1
27	#04	SM-4041055-SP	SCREW	なべねじ M4 L=10	2
28	#04	B2426-210-00G	NEEDLE HOLE GUIDE D=3	座繰り付き針穴ガイド 3	1
29	#05	MDP-170B2302	NEEDLE DPX17#23-2	DPX17#23-2	1
30	#06	MC-3720016-02	NEEDLE SY3355 #160-2	SY3355 #160-2	1
		NOTE (注記)	#01... SELECTIVE PARTS	選択部品	
			#02... FOR ST	ST用	
			#03... FOR JE	JE用	
			#04... TYPE G ACCESSORIE PARTS	G仕様付属品	
			#05... TYPE G ACCESSORIE PARTS (FOR ST)	G仕様付属品 (ST用)	
			#06... TYPE G ACCESSORIE PARTS (FOR JE)	G仕様付属品 (JE用)	

27. SEPARATE STROKE TYPE EXCLUSIVE PARTS

2段ストローク仕様専用部品

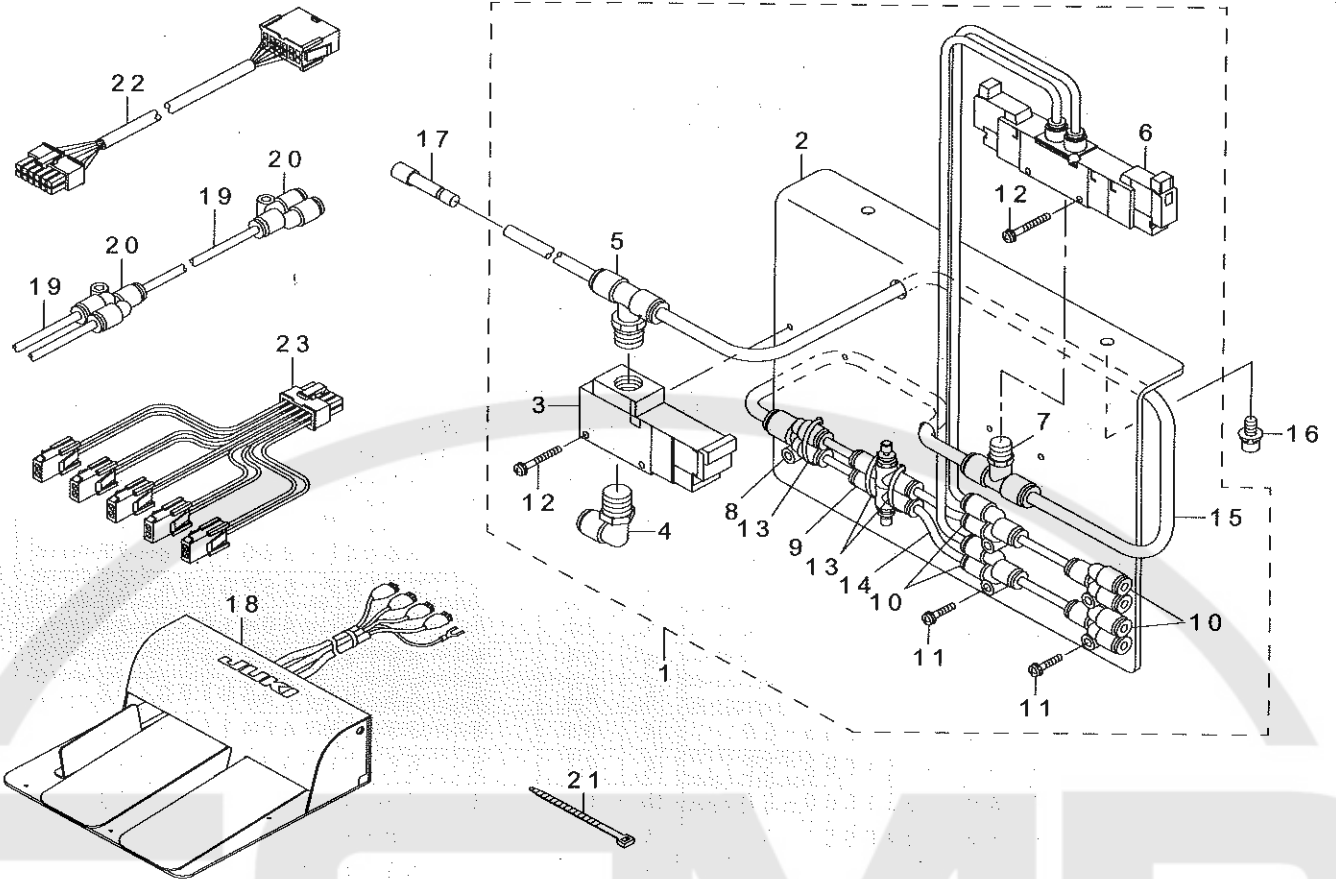

REF.NO	NOTE	PART NO	DESCRIPTION	品名	Qty
1		400-76736	SOLENOID_INSTALLING_PLATE_A_ASM.	電磁弁取付板 A 組	1
2		400-76738	SOLENOID_INSTALLING_PLATE	電磁弁取付板	(1)
3		PV-1352070-00	3-PORT ELECTROMAGNETIC VALVE	3ポート電磁弁	(1)
4		PJ-3040652-01	ELBOW UNION 6XPT1/4	エルボユニオン	(1)
5		PJ-3050652-04	DOUBLE-ENDED T UNION	両口チーズユニオン	(1)
6		PV-1551130-00	5-PORT SOLENOID VALVE	5ポート電磁弁	(1)
7		PJ-3050651-07	DOUBLE-ENDED T UNION	両口チーズユニオン	(1)
8		PJ-3080600-05	IKEI UNION	異径ユニオンワイ	(1)
9		PC-0124060-00	SPEED CONTROLLER	スピードコントローラ	(2)
10		PJ-3080400-02	QUICK COUPLING	ワンタッチ継ぎ手	(4)
11		SL-4031691-SC	SCREW M3 L=16	座金付きなべ小ねじ M3 L=16	(4)
12		SL-4032591-SC	SCREW M3X25	なべ小ねじセムス M3 X 0.5 L=25	(4)
13		EA-9500B01-00	CABLE BAND	束線バンド	(3)
14		BT-0400251-EB	URETHANE HOSE, BLACK	ウレタンホース 黒	(0.6)
15		BT-0600401-EB	TUBE	チューブ	(1.1)
16		SL-6051292-TN	BOLT	座金付き六角穴ボルト	2
17		PX-9500010-00	PLUG	止栓	1
18		GPK-470010AB	3-PEDAL ASM.	3連ペダル組	1
19		BT-0400251-EB	URETHANE HOSE, BLACK	ウレタンホース 黒	1.7
20		PJ-3080400-02	QUICK COUPLING	ワンタッチ継ぎ手	4
21		EA-9500B01-00	CABLE BAND	束線バンド	3
22		400-74127	AIR EXTENSION CODE ASM.	エア-延長コード組	1
23		400-33875	PK47 RELAY CABLE ASM	PK 47中継ケーブル組	1

28. LIST FOR INFORMATION OF CHANGE

変更情報リスト

As to the place changed, refer to the corresponding Rev. No.
 When previous parts (Obsoleted part) and new parts (Added parts) are not interchangeable with each other:
 In this case, even obsoleted parts (D.) can be ordered with the obsoleted part number, so select the parts with changed dates and place your orders.

変更箇所は、該当Rev. No. 版をご参照ください。
 部品の互換性がない変更の場合は、削除された品番でも、ご注文できます。

40072222

No. 1509-01 Rev. No.

*A: Added parts 追加部品 / D: Obsoleted parts 削除部品 / E: Erratum 訂正

* Rev. No.	Page 頁	Ref. No.	Parts No. 品番	* Rev. No.	Page 頁	Ref. No.	Parts No. 品番
				A	01	2	53 B1114-280-000
D	00	6	33 SM-4040855-SP	A	01	6	33 SM-4041055-SP
D	00	6	66 SL-9061693-SE	A	01	6	66 SL-9061600-SF
D	00	6	73 WP-0531000-SD	A	01	6	73 WP-0520656-SA
D	00	6	78 SM-4040601-SC	A	01	6	78 SL-4041091-SC
				A	01	6	88 400-82017
				A	01	6	89 HX-0030700-0D
D	00	8	33 SM-4040855-SP	A	01	8	33 SM-4041055-SP
D	00	8	66 SL-9061693-SE	A	01	8	66 SL-9061600-SF
D	00	8	73 WP-0531000-SD	A	01	8	73 WP-0520656-SA
D	00	8	78 SM-4040601-SC	A	01	8	78 SL-4041091-SC
				A	01	8	88 400-82017
				A	01	8	89 HX-0030700-0D
D	00	22	3 SM-1040870-TP	A	01	22	3 SM-1040650-TP
D	00	26	11 SM-6051202-TP	A	01	26	11 SM-6051402-TP
D	00	26	38 WP-0430800-SD				
D	00	26	59 SM-6052502-TP	A	01	26	59 SM-6053052-TN
D	00	28	38 WP-0430800-SD				
				A	01	32	61 CM-3002000-03
				A	01	34	20 269-10059
D	00	36	44 SL-4041091-SC	A	01	36	44 SL-4040891-SC
D	00	38	61 SM-9086513-SC	A	01	38	61 SM-6087002-TN
D	00	42	39 SL-4041091-SC	A	01	42	39 SL-4040891-SC
				A	01	42	45 HX-0015000-0B
				A	01	42	46 SL-4041091-SC
D	00	44	32 SM-1041201-SC	A	01	44	32 SM-1041401-SN
				A	01	45	- ALL PARTS 全部品
				A	01	46	- ALL PARTS 全部品

NUMERICAL INDEX OF PARTS

索引

PART NO	PAGE	REF	PART NO	PAGE	REF	PART NO	PAGE	REF	PART NO	PAGE	REF
品番	頁	NO	品番	頁	NO	品番	頁	NO	品番	頁	NO
A1230-500-000-A	10	48	B2414-280-0A0	22	34	B9121-012-000	6	87	HD-0020400-0B	40	61
A1230-500-000-A	18	64	B2414-280-0A0	45	10	B9121-012-000	8	87	HD-0027800-00	14	54
BME-01100000	36	36	B2415-280-0A0	22	32	B9121-220-0A0	44	16	HD-0027800-00	22	20
BME-03200000	36	37	B2415-280-0A0	45	8	B9140-372-000	44	10	HD-0027800-00	30	15
BT-0400251-EB	32	18	B2416-280-000	22	31	B9141-372-000	44	11	HD-0027800-00	40	27
BT-0400251-EB	43	15	B2416-280-000	45	7	CM-1001000-01	4	32	HF-0013031-5S	36	40
BT-0400251-EB	43	16	B2417-210-000	22	36	CM-2001000-01	38	49	HF-0013050-P0	36	42
BT-0400251-EB	43	17	B2417-210-000	45	12	CM-3001000-03	36	34	HF-0030002-00	36	41
BT-0400251-EB	43	21	B2417-280-000	22	38	CM-3001004-01	36	32	HK-0346100-20	19	17
BT-0400251-EB	43	22	B2417-280-000	45	14	CM-3002000-03	32	61	HK-0346100-40	33	19
BT-0400251-EB	46	14	B2418-280-000	22	30	CM-3002000-03	32	61	HK-0346400-0B	19	18
BT-0400251-EB	46	19	B2418-280-000	45	6	CM-3004006-01	36	35	HK-0346400-00	33	20
BT-0600401-EB	33	8	B2421-210-AA0	22	29	CM-3004007-01	36	33	HN-0014900-00	38	47
BT-0600401-EB	46	15	B2421-210-AA0	45	5	CM-3012000-01	4	1	HN-0028400-00	22	16
B1111-220-000-A	6	1	B2423-280-00A	22	41	CM-6001001-01	4	33	HW-2003900-00	19	20
B1111-220-000-A	8	1	B2423-280-00A	45	17	CM-6001001-01	36	16	HW-5000700-00	19	21
B1114-280-000	2	53	B2423-280-00B	22	40	CM-6001001-01	38	52	HX-0006500-0A	36	29
B1115-220-000	6	2	B2423-280-00B	45	18	CM-6001002-01	44	26	HX-0014700-0J	38	58
B1115-220-000	8	2	B2423-280-00C	22	42	CQ-2000000-00	16	13	HX-0015000-0B	42	45
B1120-223-C00	6	3	B2423-280-00C	45	19	CQ-2000000-00	18	69	HX-0015000-0C	22	43
B1120-223-C00	8	3	B2423-280-00D	22	39	CQ-3030000-00	12	3	HX-0015000-0D	4	35
B1129-210-000	2	19	B2423-280-00D	45	20	CS-079073A-SH	12	33	HX-0015000-0F	4	34
B1131-528-000	44	21	B2424-210-A00	45	4	CS-0800881-TP	14	11	HX-0015000-0H	4	36
B1144-210-000	10	45	B2424-210-000	22	28	CS-0800881-TP	14	29	HX-0015000-0I	42	38
B1144-210-000	18	61	B2426-210-00B	22	27	CS-0800971-TP	16	43	HX-0015000-0J	36	30
B1157-215-000	6	27	B2426-210-00F	45	3	CS-1200981-TP	26	90	HX-0023300-00	32	19
B1157-215-000	8	27	B2426-210-00G	45	28	CS-1200981-TP	28	90	HX-0030700-0D	6	89
B1158-224-C00	26	80	B2525-223-C00	30	1	D7133-555-B00	2	51	HX-0030700-0D	8	89
B1158-224-C00	28	80	B2526-223-C00	30	2	D8001-D15-A0Y	43	3	HX-0031400-0A	43	18
B1182-223-C00	6	24	B2534-223-C00	26	19	D8002-D15-A0Y	43	28	HX-0032600-0B	42	26
B1182-223-C00	8	24	B2535-210-000	45	25	EA-9500B01-00	4	37	HX-0032600-0G	42	28
B1193-223-C00	6	26	B2537-221-D00	30	14	EA-9500B01-00	14	50	HX-0032600-0K	38	45
B1193-223-C00	8	26	B2539-223-C00	26	22	EA-9500B01-00	16	32	HX-0032600-0M	42	27
B1212-210-D00	10	44	B2539-223-C00	28	22	EA-9500B01-00	26	97	HX-0033900-00	6	64
B1212-210-D00	18	60	B2548-223-C00	26	30	EA-9500B01-00	26	97	HX-0033900-00	8	64
B1213-210-D00	10	46	B2548-223-C00	28	30	EA-9500B01-00	28	11	HX-0033900-00	38	18
B1213-210-D00	18	62	B2549-223-C00	26	31	EA-9500B01-00	33	9	HX-0035400-0N	36	6
B1228-232-000	20	46	B2549-223-C00	26	31	EA-9500B01-00	33	9	HX-0035400-0S	36	7
B1408-180-000	12	32	B2560-220-000	28	31	EA-9500B01-00	33	21	HX-0036400-0E	32	60
B1411-552-0A0	10	58	B2560-220-000	32	47	EA-9500B01-00	38	48	HX-0040700-00	38	26
B1411-804-A00	16	46	B2563-215-000	32	57	EA-9500B01-00	42	40	HX-0041000-0A	38	32
B1411-804-B00	16	47	B2564-223-C00	44	15	EA-9500B01-00	43	19	HX-0041800-0E	38	57
B1411-804-C00	16	48	B2567-223-CA0	32	30	EA-9500B01-00	46	13	HX-0051100-00	38	39
B1411-804-D00	16	49	B2567-223-C00	32	31	EA-9500B01-00	46	21	KM-0000004-80	38	23
B1414-555-000	10	59	B2568-223-C00	32	20	EA-9500B02-00	4	38	MC-3720011-00	10	38
B1504-210-000	32	3	B2568-224-C00	32	27	EA-9500B02-00	14	57	MC-3720011-02	44	5
B1519-026-00G	26	83	B2569-229-000	32	36	E2678-453-000	33	23	MC-3720016-00	45	24
B1519-026-00G	28	83	B2591-220-000	32	34	E9567-319-000	38	41	MC-3720016-02	45	30
B1601-210-D0B-A	45	22	B2611-223-CA0	44	29	E9607-603-000	38	40	MDP-170B1800	10	37
B1611-210-00A	12	48	B2611-223-C00	2	41	GAF-01007000	10	49	MDP-170B1802	44	4
B1634-210-D00	12	53	B3120-372-000	2	50	GAF-01007000	18	65	MDP-170B2300	45	23
B1636-581-A00	12	15	B3126-012-000	18	48	GBR-0118500A	24	39	MDP-170B2302	45	29
B1636-581-B00	12	16	B3509-280-000	18	47	GCT-02906000	44	12	M3004-511-00A	36	39
B1636-581-C00	12	17	B3518-280-000	45	26	GEP-01013000	40	57	M3801-476-000	38	6
B1636-581-D00	12	18	B3532-223-C00	16	38	GPK-470010AB	46	18	M4206-461-000	38	10
B1641-562-000	14	41	B3538-112-000	26	79	GPK-470010AB	33	17	M8512-581-0A0	36	47
B1802-180-000	26	47	B4022-221-D00	32	8	G6113-875-00A	6	74	M9017-580-0A0	40	15
B1802-180-000	28	47	B4022-221-D00	32	9	G6113-875-00A	8	74	M9029-580-0A0	38	53
B1806-210-D00	16	31	B4711-220-00C	32	10	G8124-270-000	33	14	M9034-580-0A0	36	23
B1806-210-D00	44	1	B4711-220-00D	32	11	HA-0042500-00	36	27	M9035-580-0A0	36	22
B1816-215-P00	22	48	B4711-220-00E	32	12	HA-0042500-00	40	12	M9035-580-0A0	40	14
B1816-280-000	26	84	B4715-215-0A0	6	85	HA-0058200-00	36	28	NM-3040520-SC	38	19
B1816-280-000	28	84	B8111-220-000	8	85	HA-0058200-00	40	13	NM-3040520-SC	38	25
B1816-280-000	32	35	B8112-220-000	8	83	HA-0060000-00	19	19	NM-3050610-SF	6	13
B1820-210-D00	16	3	B8112-220-000	8	83	HD-0005700-0A	14	48	NM-3050610-SF	8	13
B1821-210-D00	16	4	B8117-223-C00	42	22	HD-0005700-0A	22	17	NM-6040000-SN	2	15
B1822-215-P00	16	5	B8118-223-C00	42	23	HD-0005700-0A	26	40	NM-6040001-SC	44	34
B1828-210-DAA	16	30	B8171-220-000	6	84	HD-0005700-0A	28	40	NM-6040001-SP	22	9
B1847-221-D00	16	45	B8202-205-000	8	84	HD-0005700-0A	40	59	NM-6040002-SE	34	26
B1903-552-000	10	28	B8601-WP1-0A0	44	30	HD-0020400-0A	24	35	NM-6040002-SE	34	29
B1908-505-000	10	19	B9101-490-000	44	24	HD-0020400-0A	40	60	NM-6040003-SC	20	18
B2107-210-D00	19	2	B9113-012-000	44	9	HD-0020400-0B	24	36	NM-6050001-SE	34	13
B2110-210-D00	19	41									
B2130-210-D00	19	11									

NUMERICAL INDEX OF PARTS

索引

PART NO 品番	PAGE 頁	REF NO	PART NO 品番	PAGE 頁	REF NO	PART NO 品番	PAGE 頁	REF NO	PART NO 品番	PAGE 頁	REF NO
NM-6050001-SE	34	17	SB-1040016-00	10	21	SL-4032591-SC	46	12	SM-4041001-SC	6	36
NM-6050001-SP	22	12	SB-1080005-00	14	26	SL-4040691-SC	36	31	SM-4041001-SC	8	36
NM-6050001-SP	26	37	SB-1080005-00	26	43	SL-4040881-SC	38	14	SM-4041001-SC	34	25
NM-6050001-SP	28	37	SB-1080005-00	28	43	SL-4040881-SC	38	17	SM-4041055-SP	2	5
NM-6080001-SC	38	9	SB-1080022-00	10	20	SL-4040881-SC	38	21	SM-4041055-SP	2	32
NM-6080001-SC	38	64	SB-1080023-00	10	24	SL-4040891-SC	4	2	SM-4041055-SP	6	33
NM-6080001-SC	42	37	SB-1100024-00	22	52	SL-4040891-SC	4	30	SM-4041055-SP	8	33
NM-6100001-SE	42	15	SB-1120002-00	18	57	SL-4040891-SC	6	63	SM-4041055-SP	19	38
NM-6120001-SE	42	16	SB-1150006-00	26	44	SL-4040891-SC	8	63	SM-4041055-SP	45	27
NM-6120011-SF	6	5	SB-1150006-00	28	44	SL-4040891-SC	33	11	SM-4041201-SC	34	27
NM-6120011-SF	8	5	SB-1150014-00	18	29	SL-4040891-SC	36	44	SM-4041255-SP	32	44
NM-6160001-SC	42	17	SB-1170004-00	18	2	SL-4040891-SC	38	4	SM-4041401-SC	6	37
NM-6160511-SE	34	18	SB-1170009-00	26	46	SL-4040891-SC	38	5	SM-4041401-SC	8	37
NS-6090310-SP	19	22	SB-1170009-00	28	46	SL-4040891-SC	38	12	SM-4042001-SC	34	28
NS-6110310-SP	2	48	SB-1170010-00	18	5	SL-4040891-SC	38	38	SM-4050855-SP	19	37
NS-6110310-SP	19	23	SB-1170011-00	18	14	SL-4040891-SC	42	39	SM-4051001-SN	6	14
			SB-1200009-00	10	1	SL-4041081-SC	38	51	SM-4051001-SN	8	14
PA-1602509-A0	32	6	SB-1200017-00	10	6	SL-4041091-SC	6	48	SM-4051055-SP	2	29
PB-0000100-00	44	18	SB-1200018-00	10	4	SL-4041091-SC	6	78	SM-4051255-SP	26	70
PC-0124010-00	32	26	SB-1300002-00	26	48	SL-4041091-SC	8	48	SM-4051255-SP	28	70
PC-0124060-00	46	9	SB-1300002-00	28	48	SL-4041091-SC	8	78	SM-4051405-SE	34	12
PF-0552040-B0	33	13	SB-1300003-00	26	49	SL-4041091-SC	36	45	SM-4051655-SP	22	50
PJ-0305200-01	33	16	SB-1300003-00	28	49	SL-4041091-SC	38	28	SM-4055001-SF	6	6
PJ-0460525-03	32	7	SB-3070002-0A	10	29	SL-4041091-SC	38	50	SM-4055001-SF	8	6
PJ-3010405-01	43	13	SB-3070002-0B	10	30	SL-4041091-SC	42	30	SM-4061255-SP	2	2
PJ-3010405-05	33	3	SB-3070002-0C	10	31	SL-4041091-SC	42	46	SM-4061255-SP	2	13
PJ-3010600-03	33	10	SB-3070002-0D	10	32	SL-4043591-SC	38	24	SM-4061255-SP	18	50
PJ-3010651-03	33	6	SB-3080010-0A	16	21	SL-4051091-SC	33	24	SM-5040655-SN	4	24
PJ-3040652-01	46	4	SB-3080010-0B	16	22	SL-6040892-TN	2	34	SM-6020250-TP	16	36
PJ-3050651-07	46	7	SB-3080010-0C	16	23	SL-6040892-TN	18	46	SM-6020350-SP	24	13
PJ-3050652-02	33	15	SB-3080010-0D	16	24	SL-6051292-TN	46	16	SM-6020450-TP	24	37
PJ-3050652-04	46	5	SB-3100011-0A	18	25	SL-6052592-TN	10	41	SM-6020460-TP	16	9
PJ-3080400-02	43	27	SB-3100011-0B	18	26	SL-6061292-TN	42	44	SM-6020460-TP	16	26
PJ-3080400-02	46	10	SB-3100011-0C	18	27	SL-6062592-TN	32	21	SM-6030602-TP	24	14
PJ-3080400-02	46	20	SB-3100011-0D	18	28	SL-6082092-TN	38	60	SM-6030602-TP	26	50
PJ-3080600-05	46	8	SB-3120006-00	26	87	SL-6083092-TN	38	7	SM-6030602-TP	28	50
PJ-3090052-03	33	18	SB-3120006-00	28	87	SL-9061600-SF	6	66	SM-6031002-TP	26	32
PJ-3095200-01	44	17	SB-3350002-0A	18	17	SL-9061600-SF	8	66	SM-6031002-TP	28	32
PS-0150065-KP	6	67	SB-3350002-0B	18	18	SL-9082093-SE	42	18	SM-6031402-TP	26	51
PS-0150065-KP	8	67	SB-3350002-0C	18	19	SM-1030601-SP	6	32	SM-6031402-TP	28	51
PS-0150065-KP	32	32	SB-3350002-0D	18	20	SM-1030601-SP	8	32	SM-6040450-TP	26	82
PS-0250062-KH	6	28	SB-3350002-0E	18	21	SM-1030601-SP	18	24	SM-6040450-TP	28	82
PS-0250062-KH	8	28	SB-4080001-00	14	13	SM-1040650-TP	22	3	SM-6040602-TP	14	51
PS-0400141-KH	42	29	SB-4120001-00	30	3	SM-1040801-SP	6	31	SM-6040602-TP	16	39
PS-0400142-KH	10	47	SB-6120001-00	26	89	SM-1040801-SP	8	31	SM-6040602-TP	24	32
PS-0400142-KH	18	63	SB-6120001-00	28	89	SM-1040870-TP	6	30	SM-6040602-TP	26	35
PV-0105020-00	43	12	SD-0350156-TP	24	27	SM-1040870-TP	6	65	SM-6040602-TP	26	96
PV-1351270-A0	33	5	SD-0400266-TP	24	8	SM-1040870-TP	8	30	SM-6040602-TP	28	9
PV-1352070-00	46	3	SD-0650321-TP	19	28	SM-1040870-TP	8	65	SM-6040602-TP	28	35
PV-1502091-00	33	4	SD-0800327-TP	22	11	SM-1040870-TP	18	39	SM-6040650-TP	2	17
PV-1551130-00	46	6	SD-0800336-TP	12	59	SM-1040870-TP	32	50	SM-6040650-TP	2	20
PV-9150050-00	33	2	SD-0800337-TP	14	25	SM-1041401-SN	44	32	SM-6040650-TP	2	22
PX-0200020-00	43	11	SD-0800346-TP	18	52	SM-1041601-SC	6	76	SM-6040650-TP	2	44
PX-0551040-00	33	7	SD-0800386-TP	12	35	SM-1041601-SC	8	76	SM-6040650-TP	6	35
PX-5000140-00	43	14	SD-0800387-TP	14	40	SM-1061201-SN	42	21	SM-6040650-TP	8	35
PX-9500010-00	46	17	SD-0800407-TP	24	25	SM-2360110-TP	24	20	SM-6040650-TP	18	41
PX-9500090-00	33	22	SD-0800408-TP	12	38	SM-4020501-SC	14	55	SM-6040650-TP	22	53
			SD-0800656-TP	12	60	SM-4020501-SC	22	21	SM-6040650-TP	24	21
RC-0560711-KP	4	21	SD-0800746-TP	12	10	SM-4020501-SC	30	12	SM-6040802-TP	4	39
RC-0650811-KP	12	25	SD-1000506-TP	12	37	SM-4020600-SP	24	18	SM-6040802-TP	6	57
RC-1200001-KP	18	59	SD-1002206-TP	12	58	SM-4030401-SC	6	29	SM-6040802-TP	6	82
RC-3781518-KP	12	20	SK-3271301-SE	42	42	SM-4030401-SC	8	29	SM-6040802-TP	8	57
RE-0200000-K0	24	7	SK-3413201-SE	36	20	SM-4030455-SP	16	12	SM-6040802-TP	8	82
RE-0250000-K0	19	24	SK-3512001-SE	36	46	SM-4030501-SF	36	10	SM-6040802-TP	12	52
RE-0300000-K0	16	6	SL-4030641-SE	19	30	SM-4030501-SF	36	15	SM-6040802-TP	20	2
RE-0300000-K0	32	12	SL-4030691-SC	36	8	SM-4030601-SN	2	9	SM-6040802-TP	20	9
RE-0320000-K0	32	25	SL-4030691-SC	36	9	SM-4030601-SN	2	36	SM-6040802-TP	20	16
RE-0400000-K0	4	22	SL-4030881-SC	38	59	SM-4030601-SN	19	29	SM-6040802-TP	22	44
RE-0500000-K0	19	25	SL-4031091-SC	14	49	SM-4040501-SN	44	35	SM-6040802-TP	22	51
RE-0600000-K0	26	39	SL-4031091-SC	22	18	SM-4040655-SP	2	42	SM-6040802-TP	26	42
RE-0600000-K0	28	39	SL-4031091-SC	26	41	SM-4040655-SP	6	34	SM-6040802-TP	28	42
RE-0700000-K0	14	35	SL-4031091-SC	28	41	SM-4040655-SP	8	34	SM-6040860-TP	2	18
RE-0800000-K0	18	37	SL-4031481-SC	6	86	SM-4040855-SP	2	7	SM-6040860-TP	20	13
RE-0900000-K0	20	3	SL-4031481-SC	8	86	SM-4040855-SP	2	38	SM-6040860-TP	44	23
			SL-4031691-SC	46	11	SM-4040855-SP	19	36	SM-6041150-TP	4	27

NUMERICAL INDEX OF PARTS

索引

PART NO 品番	PAGE 頁	REF NO	PART NO 品番	PAGE 頁	REF NO	PART NO 品番	PAGE 頁	REF NO	PART NO 品番	PAGE 頁	REF NO
SM-6041202-TP	24	29	SM-8050412-TP	26	53	TA-1050504-R0	2	24	WP-0641601-SD	18	54
SM-6041202-TP	24	31	SM-8050412-TP	26	62	TA-1050504-R0	18	71	WP-0651001-SC	22	47
SM-6041202-TP	26	52	SM-8050412-TP	26	69	TA-2100904-R0	2	10	WP-0820516-SP	10	15
SM-6041202-TP	26	54	SM-8050412-TP	26	73	TA-2100904-R0	6	75	WP-0841601-SC	38	8
SM-6041202-TP	26	55	SM-8050412-TP	28	53	TA-2100904-R0	8	75	WP-0841601-SC	38	62
SM-6041202-TP	26	56	SM-8050412-TP	28	62	TA-2351004-R0	2	27	WP-0841601-SC	42	32
SM-6041202-TP	28	52	SM-8050412-TP	28	69				WP-0841601-SC	42	33
SM-6041202-TP	28	54	SM-8050412-TP	28	73	WP-0220301-SC	14	56	WP-0850002-SP	14	14
SM-6041202-TP	28	55	SM-8050412-TP	32	48	WP-0220301-SC	22	22	WP-1221016-SP	12	27
SM-6041202-TP	28	56	SM-8050502-TP	4	25	WP-0220301-SC	30	13	WP-1221016-SP	18	58
SM-6041402-TN	6	70	SM-8050512-TP	16	44	WP-0320500-SC	24	6	WP-1302501-SC	42	10
SM-6041402-TN	8	70	SM-8050592-TP	22	2	WP-0320500-SD	24	16	WP-1302501-SE	6	10
SM-6041402-TP	14	21	SM-8050592-TP	22	55	WP-0320501-SC	19	31	WP-1302501-SE	8	10
SM-6041602-TP	10	40	SM-8050592-TP	26	91	WP-0320501-SD	26	36	WP-1702600-S0	34	19
SM-6050652-TP	26	77	SM-8050592-TP	28	91	WP-0320501-SD	26	68	WS-0451040-KP	2	52
SM-6050652-TP	28	77	SM-8050612-TP	26	75	WP-0320501-SD	28	36	WS-0451040-KP	43	5
SM-6050800-SP	26	66	SM-8050612-TP	28	75	WP-0320501-SD	28	68	WS-0451040-KP	43	9
SM-6050800-SP	26	85	SM-8050812-TP	32	15	WP-0330501-SB	6	38	WS-0510002-KN	34	16
SM-6050800-SP	28	66	SM-8050812-TP	32	22	WP-0330501-SB	8	38	WS-0610002-KP	32	38
SM-6050800-SP	28	85	SM-8060552-TP	16	42	WP-0430800-SC	12	54	WS-0820002-KN	38	63
SM-6050800-SP	32	16	SM-8060552-TP	18	32	WP-0430800-SD	26	45	WS-0820002-KN	42	34
SM-6050800-SP	32	58	SM-8060552-TP	26	95	WP-0430800-SD	28	45	WS-0820002-KN	42	35
SM-6050802-TP	6	72	SM-8060602-TP	28	95	WP-0430800-SD	32	45	WS-1220002-KN	42	11
SM-6050802-TP	8	72	SM-8060602-TP	14	19	WP-0430801-SC	20	10	WS-1253010-KN	6	11
SM-6050802-TP	14	45	SM-8060602-TP	30	7	WP-0430801-SC	44	33	WS-1253010-KN	8	11
SM-6051002-TP	26	65	SM-8060602-TP	30	8	WP-0450000-SD	6	40	WZ-0850302-K0	14	28
SM-6051002-TP	28	65	SM-8060610-TP	16	34	WP-0450000-SD	8	40			
SM-6051002-TP	32	23	SM-8060802-TP	26	63	WP-0450000-SD	2	39	101-02200	44	22
SM-6051202-TP	26	57	SM-8060802-TP	28	63	WP-0450801-SD	6	39	105-02300	2	35
SM-6051202-TP	26	61	SM-8060812-TP	10	3	WP-0450801-SD	8	39	110-72402	2	47
SM-6051202-TP	26	67	SM-8060812-TP	10	43	WP-0450801-SD	43	4	111-11051	19	13
SM-6051202-TP	28	57	SM-8060812-TP	12	6	WP-0450801-SD	43	8	122-09706	6	77
SM-6051202-TP	28	61	SM-8060812-TP	12	12	WP-0450801-SP	6	56	122-09706	8	77
SM-6051202-TP	28	67	SM-8060812-TP	14	16	WP-0450801-SP	6	58	131-22403	12	23
SM-6051402-TP	26	11	SM-8060812-TP	14	18	WP-0450801-SP	8	56	131-22452	12	22
SM-6051402-TP	26	58	SM-8060812-TP	14	32	WP-0450801-SP	8	58	131-67903	34	21
SM-6051402-TP	28	58	SM-8060812-TP	14	34	WP-0450801-SP	19	39	131-68000	34	22
SM-6051402-TP	30	9	SM-8060812-TP	18	4	WP-0450801-SP	24	2	131-68109	34	23
SM-6051602-TP	18	12	SM-8060812-TP	18	16	WP-0450826-SC	4	23	131-68208	34	24
SM-6051602-TP	26	71	SM-8060812-TP	22	14	WP-0450846-SP	14	52	135-18501	18	55
SM-6051602-TP	28	71	SM-8060812-TP	26	64	WP-0450846-SP	22	37	135-29607	16	15
SM-6051602-TP	30	6	SM-8060812-TP	28	64	WP-0450846-SP	45	13	137-04705	44	6
SM-6051802-TP	32	37	SM-8061050-TP	16	37	WP-0510516-SD	20	45	137-05108	2	21
SM-6052502-TP	26	60	SM-8061612-TP	10	36	WP-0520656-SA	6	73	138-16855	6	44
SM-6052502-TP	28	59	SM-8061612-TP	20	47	WP-0520656-SA	8	73	138-16855	8	44
SM-6052502-TP	28	60	SM-8480652-TP	14	10	WP-0520656-SA	14	38	138-87005	26	88
SM-6053052-TN	26	59	SM-8480652-TP	18	34	WP-0522016-SH	14	39	138-87005	28	88
SM-6060800-SP	16	18	SM-9087533-SC	42	31	WP-0531000-SD	18	13	141-03352	16	27
SM-6060802-TP	32	29	SM-9124503-SB	6	7	WP-0531000-SD	26	25	141-03659	45	21
SM-6061010-TP	18	53	SM-9124503-SB	8	7	WP-0531000-SD	26	38	141-03907	16	10
SM-6061202-TP	6	42	SM-9129013-SB	42	19	WP-0531000-SD	26	76	141-04004	16	8
SM-6061202-TP	8	42	SS-1060210-TP	22	35	WP-0531000-SD	26	78	141-13450	2	49
SM-6061402-TP	12	24	SS-1060210-TP	45	11	WP-0531000-SD	26	86	141-13468	2	46
SM-6061610-SC	34	6	SS-1110640-TP	12	30	WP-0531000-SD	26	93	141-15554	4	31
SM-6061802-TP	14	22	SS-6090910-SP	12	41	WP-0531000-SD	28	25	141-15554	40	62
SM-6061802-TP	22	46	SS-6110430-TP	22	24	WP-0531000-SD	28	38	144-32504	18	56
SM-6062502-TN	32	54	SS-6110430-TP	45	16	WP-0531000-SD	28	76	168-70206	42	36
SM-6087002-TN	38	61	SS-6111210-SP	43	7	WP-0531000-SD	28	78	178-45009	38	27
SM-6450610-TP	6	55	SS-6151612-TP	32	41	WP-0531000-SD	28	86	180-35204	43	23
SM-6450610-TP	8	55	SS-7090410-SP	22	33	WP-0531000-SD	28	93	180-35303	43	24
SM-7030450-SC	6	71	SS-7090410-SP	45	9	WP-0531000-SD	30	10	180-35600	43	25
SM-7030450-SC	8	71	SS-7110740-TP	22	26	WP-0531000-SD	30	11	180-35709	43	26
SM-7751160-TP	12	51	SS-7110740-TP	45	15	WP-0531000-SD	32	17			
SM-8030412-TP	10	63	SS-7111120-TP	43	6	WP-0531000-SD	32	24	228-91006	10	25
SM-8030412-TP	20	7	SS-7111810-TP	12	42	WP-0531000-SD	32	59	228-91204	10	34
SM-8040310-SS	10	51	SS-8110410-TP	12	34	WP-0531001-SC	19	40	229-01409	10	62
SM-8040310-SS	10	53	SS-8660512-TP	18	8	WP-0553216-SD	43	10	229-01805	4	3
SM-8040412-TP	19	26	SS-8660512-TP	26	92	WP-0561616-SC	6	9	229-02506	2	4
SM-8040412-TP	19	27	SS-8660512-TP	28	92	WP-0561616-SC	8	9	229-07505	12	45
SM-8040502-TP	18	10	SS-9151240-SN	6	8	WP-0611626-SP	12	9	229-07554	12	44
SM-8040502-TP	18	67	SS-9151240-SN	8	8	WP-0611626-SP	32	39	229-07604	12	46
SM-8040802-TP	4	26				WP-0641600-SC	32	42	229-20508	2	16
SM-8050412-TP	14	12	TA-0550604-R0	12	61	WP-0641600-SC	32	55	229-21506	20	29
SM-8050412-TP	14	30	TA-0750404-R0	12	21	WP-0641601-SC	6	43	229-28808	20	28
SM-8050412-TP	14	43	TA-0850604-R0	2	23	WP-0641601-SC	8	43	229-30309	34	14

NUMERICAL INDEX OF PARTS

索引

PART NO	PAGE	REF	PART NO	PAGE	REF	PART NO	PAGE	REF	PART NO	PAGE	REF
品番	頁	NO	品番	頁	NO	品番	頁	NO	品番	頁	NO
229-30358	34	1	400-05393	38	33	400-10515	20	40	400-30625	14	1
229-30408	34	10	400-05393	40	18	400-10521	20	43	400-30626	14	2
229-30507	34	9	400-05394	38	35	400-10522	20	44	400-30627	14	3
229-30705	34	7	400-05394	40	20	400-10523	20	33	400-30628	12	62
229-30804	34	5	400-05401	38	22	400-10527	24	22	400-30629	12	63
229-30903	34	4	400-05401	40	8	400-10528	24	23	400-30630	12	64
229-31000	34	3	400-05706	38	20	400-10533	10	54	400-30779	19	12
229-31109	34	2	400-05726	38	36	400-10589	24	9	400-30780	19	5
229-31208	34	15	400-05726	40	21	400-11152	24	24	400-30828	2	8
229-31307	34	11	400-05727	38	37	400-11902	10	35	400-30829	4	15
229-31406	34	8	400-05727	40	22	400-12038	38	34	400-30926	36	4
229-32800	44	27	400-05848	36	5	400-12038	40	19	400-30933	22	23
229-33006	44	28	400-06323	44	13	400-12965	12	19	400-30934	22	25
229-33105	44	19	400-06484	2	37	400-13640	4	29	400-30934	45	2
229-33204	44	14	400-06515	10	50	400-14963	16	28	400-30936	22	1
229-55504	19	4	400-06515	18	66	400-15800	24	5	400-30942	24	17
229-55900	19	7	400-06516	10	52	400-18948	38	44	400-30943	24	15
229-56007	19	8	400-06529	10	16	400-23371	40	17	400-30956	19	6
229-56106	19	9	400-06530	10	17	400-23624	22	13	400-31336	4	28
229-56205	19	10	400-06531	10	18	400-23631	12	49	400-32158	2	1
229-56908	19	14	400-06532	10	26	400-23632	12	50	400-32159	2	26
229-57104	19	15	400-06534	10	22	400-23635	32	5	400-32179	14	7
229-57203	19	16	400-06535	10	23	400-23644	32	2	400-32180	14	17
235-17501	22	4	400-06537	10	27	400-23865	4	13	400-32181	14	23
235-17600	22	5	400-06574	16	2	400-23866	4	14	400-32229	32	13
235-17709	22	6	400-06576	16	20	400-23993	20	12	400-32230	32	14
235-17808	22	7	400-06577	16	11	400-23999	20	15	400-32343	20	11
236-04200	10	2	400-06578	16	33	400-24988	12	29	400-32345	20	14
236-04309	10	42	400-06617	20	5	400-24989	14	24	400-32483	14	6
236-10108	12	39	400-06622	20	25	400-24991	12	40	400-32763	44	25
236-18606	18	7	400-06625	20	4	400-24997	6	41	400-32798	12	43
236-18606	26	34	400-06666	22	54	400-24997	8	41	400-33831	40	55
236-18606	28	34	400-06761	24	1	400-24999	2	6	400-33831	43	1
236-30007	16	14	400-06762	24	3	400-25011	12	13	400-33875	40	56
236-30007	18	70	400-06765	24	4	400-25012	12	5	400-33875	46	23
260-23408	32	4	400-06768	24	19	400-25014	6	54	400-35024	36	48
262-11904	2	12	400-06772	24	10	400-25014	8	54	400-36117	16	25
262-18602	20	31	400-06780	24	11	400-25016	14	31	400-36118	16	35
262-21101	6	47	400-06781	24	12	400-25030	14	36	400-37500	19	32
262-21101	8	47	400-06836	2	43	400-25414	2	14	400-37501	19	33
262-21200	6	46	400-06840	2	45	400-25415	12	8	400-40230	6	62
262-21200	8	46	400-06840	18	68	400-25416	19	3	400-40230	8	62
262-26001	14	42	400-10415	10	5	400-25418	14	33	400-40230	40	54
262-60109	4	5	400-10418	10	7	400-25419	14	47	400-40237	40	58
262-60208	4	6	400-10422	10	9	400-25420	14	44	400-40238	40	49
262-60307	4	7	400-10423	10	10	400-25423	14	8	400-40256	22	8
262-60406	4	8	400-10424	10	11	400-25426	14	27	400-42352	43	2
262-60505	4	9	400-10425	10	12	400-25427	12	2	400-43321	14	53
262-60604	4	10	400-10426	10	13	400-25428	12	11	400-44971	36	14
262-60703	4	11	400-10427	10	14	400-25429	12	26	400-46076	36	12
262-60802	4	12	400-10434	10	33	400-25431	12	1	400-48529	40	45
262-61206	4	16	400-10441	10	55	400-25440	19	34	400-50647	36	43
262-61305	4	17	400-10442	10	56	400-25441	19	35	400-50647	44	31
262-61503	4	18	400-10443	22	19	400-26817	14	4	400-51330	36	11
262-61602	4	19	400-10470	16	16	400-26818	18	36	400-51501	6	61
262-61701	4	20	400-10471	16	17	400-26819	14	9	400-51501	8	61
265-01858	16	7	400-10472	16	19	400-26882	10	57	400-51640	38	43
269-10059	34	20	400-10477	20	6	400-26884	10	61	400-51769	32	49
			400-10478	20	41	400-26979	2	3	400-51770	32	43
312-62801	6	45	400-10479	20	8	400-27870	14	37	400-51987	2	40
312-62801	8	45	400-10487	20	17	400-27971	2	11	400-52937	10	60
			400-10489	20	19	400-28338	4	4	400-52937	40	23
400-00029	38	13	400-10489	20	23	400-28834	2	30	400-53776	45	1
400-00029	40	2	400-10490	20	20	400-28835	2	31	400-55355	38	1
400-00046	38	16	400-10497	20	21	400-28877	2	28	400-55356	38	2
400-00046	40	4	400-10498	20	22	400-29411	20	32	400-55357	38	3
400-00056	38	15	400-10499	20	24	400-29412	20	42	400-57278	38	66
400-00056	40	3	400-10503	20	27	400-29419	12	36	400-61991	16	29
400-00140	36	19	400-10504	20	30	400-29420	14	5	400-62367	38	55
400-00146	36	3	400-10509	20	34	400-30615	14	15	400-62367	40	24
400-03458	38	42	400-10510	20	35	400-30616	12	65	400-62368	38	56
400-03970	14	46	400-10511	20	36	400-30617	12	4	400-62368	40	25
400-05390	40	16	400-10512	20	37	400-30620	12	31	400-68829	12	56
400-05392	38	30	400-10513	20	38	400-30621	12	55	400-68832	12	57
400-05392	40	10	400-10514	20	39	400-30623	12	47	400-68833	12	14

NUMERICAL INDEX OF PARTS

索引

PART NO 品番	PAGE 頁	REF NO	PART NO 品番	PAGE 頁	REF NO	PART NO 品番	PAGE 頁	REF NO	PART NO 品番	PAGE 頁	REF NO
400-68834	12	28	400-72125	28	28	400-72209	26	72	400-76738	46	2
400-68835	12	7	400-72126	26	29	400-72209	28	72	400-77782	38	65
400-71942	14	20	400-72126	28	29	400-72211	22	45	400-77782	40	63
400-71942	40	28	400-72127	26	81	400-72212	6	81	400-77848	36	1
400-71944	22	49	400-72127	28	81	400-72212	8	81	400-77848	40	6
400-71944	40	31	400-72128	26	21	400-72213	6	80	400-79638	36	24
400-71945	30	4	400-72128	28	21	400-72213	8	80	400-79639	36	25
400-71945	40	34	400-72129	26	20	400-72214	6	79	400-79640	36	26
400-72073	6	4	400-72129	28	20	400-72214	8	79	400-82017	6	88
400-72073	8	4	400-72130	26	4	400-72220	33	1	400-82017	8	88
400-72074	6	12	400-72131	26	33	400-72223	42	5			
400-72074	8	12	400-72132	28	33	400-72225	24	28			
400-72075	8	15	400-72133	26	74	400-72226	26	10			
400-72076	6	15	400-72133	28	74	400-72226	28	10			
400-72077	42	2	400-72135	32	1	400-72227	18	31			
400-72078	6	25	400-72136	32	28	400-72227	26	94			
400-72078	8	25	400-72137	32	51	400-72227	28	94			
400-72079	6	20	400-72138	32	46	400-72228	22	10			
400-72079	8	20	400-72139	32	56	400-72231	42	41			
400-72080	6	21	400-72140	16	1	400-72233	10	39			
400-72080	8	21	400-72143	6	23	400-72244	6	49			
400-72081	6	19	400-72143	8	23	400-72245	8	49			
400-72081	8	19	400-72145	42	1	400-73215	42	43			
400-72082	44	2	400-72146	42	25	400-73216	42	20			
400-72083	44	3	400-72147	44	8	400-73222	42	6			
400-72084	6	50	400-72148	44	7	400-73224	42	7			
400-72085	8	50	400-72151	19	1	400-73225	42	8			
400-72086	10	8	400-72151	40	42	400-73226	42	9			
400-72087	42	3	400-72152	26	9	400-73227	42	12			
400-72088	18	6	400-72153	28	4	400-73230	42	13			
400-72089	18	1	400-72154	44	20	400-73231	42	14			
400-72090	18	11	400-72155	30	5	400-73620	40	35			
400-72091	18	15	400-72156	26	26	400-73621	40	36			
400-72092	18	22	400-72159	18	45	400-73622	40	32			
400-72093	18	30	400-72160	26	1	400-73623	40	29			
400-72094	18	33	400-72160	28	1	400-73626	40	40			
400-72095	18	35	400-72161	32	52	400-73632	40	37			
400-72096	18	38	400-72162	32	53	400-73638	40	38			
400-72097	18	43	400-72163	32	40	400-73639	40	33			
400-72098	18	44	400-72166	26	5	400-73640	40	30			
400-72099	18	42	400-72166	28	5	400-73650	38	11			
400-72100	18	40	400-72167	26	7	400-73650	40	1			
400-72101	16	41	400-72167	28	7	400-73651	38	54			
400-72102	16	40	400-72168	26	8	400-73651	40	5			
400-72103	18	51	400-72168	28	8	400-73659	38	46			
400-72106	18	23	400-72169	26	6	400-73659	40	26			
400-72107	22	15	400-72170	28	6	400-73660	20	1			
400-72108	24	26	400-72171	26	18	400-73660	40	41			
400-72109	24	34	400-72171	28	18	400-73671	40	47			
400-72110	24	38	400-72173	18	9	400-73672	40	48			
400-72111	20	26	400-72174	6	18	400-73674	24	33			
400-72112	26	13	400-72174	8	18	400-73674	40	50			
400-72112	28	13	400-72175	6	52	400-73675	40	51			
400-72113	26	2	400-72175	8	52	400-73676	2	33			
400-72113	28	2	400-72176	6	51	400-73676	40	52			
400-72114	26	12	400-72176	8	51	400-73678	2	25			
400-72114	28	12	400-72177	6	60	400-73678	40	53			
400-72115	26	3	400-72177	8	60	400-73679	36	21			
400-72115	28	3	400-72178	6	59	400-73679	40	7			
400-72116	26	14	400-72178	8	59	400-73681	40	43			
400-72116	28	14	400-72179	6	53	400-73683	38	29			
400-72117	26	15	400-72179	8	53	400-73683	40	9			
400-72117	28	15	400-72180	8	17	400-73684	38	31			
400-72118	26	16	400-72183	8	69	400-73684	40	11			
400-72118	28	16	400-72184	6	17	400-74051	36	38			
400-72119	26	17	400-72186	6	69	400-74127	46	22			
400-72119	28	17	400-72187	8	16	400-74987	40	44			
400-72120	26	23	400-72189	8	68	400-75079	24	30			
400-72121	28	23	400-72191	6	16	400-75079	40	39			
400-72122	26	24	400-72193	6	68	400-75391	40	46			
400-72122	28	24	400-72195	6	22	400-76009	36	13			
400-72123	28	26	400-72195	8	22	400-76012	36	2			
400-72124	26	27	400-72206	42	4	400-76031	36	17			
400-72124	28	27	400-72207	18	3	400-76032	36	18			
400-72125	26	28	400-72208	18	49	400-76736	46	1			